

■ AC Power
For Business-Critical Continuity™

Liebert® GXT3™ 230V, 5000-10,000VA
User Manual



TABLE OF CONTENTS

IMPORTANT SAFETY INSTRUCTIONS	1
SAVE THESE INSTRUCTIONS	1
GLOSSARY OF SYMBOLS	3
1.0 INTRODUCTION	4
2.0 SYSTEM DESCRIPTION	5
2.1 Transient Voltage Surge Suppression (TVSS) and EMI/RFI Filters.....	5
2.2 Rectifier/Power Factor Correction (PFC) Circuit	5
2.3 Inverter	5
2.4 Battery Charger	5
2.5 DC-to-DC Converter	6
2.6 Battery	6
2.7 Dynamic Bypass	6
3.0 MAJOR COMPONENTS	7
3.1 Main Frame and Electronics	7
3.2 Internal Battery Packs	9
3.3 Removable Power Distribution Box	9
4.0 WHAT'S INCLUDED	10
5.0 INSTALLATION AND CONFIGURATION	11
5.1 Install the Main Cabinet	11
5.1.1 Tower UPS Installation	11
5.1.2 Rack-Mount UPS Installation	12
5.1.3 Installing the Adjustable Rack-Mount Kit—Sold Separately	12
5.2 External Battery Cabinet Installation	14
5.3 Connect Input/Output Power	16
5.3.1 Distribution Box Electrical Connections	17
6.0 CONFIGURATION PROGRAM	18
6.1 Configuration Program Features	18
6.1.1 What You Will Need	18
7.0 CONTROLS AND INDICATORS	19
7.1 ON/Alarm Silence/Manual Battery Test Button	19
7.2 Standby/Manual Bypass Button	19
7.3 Load Level Indicators (4 Green, 1 Amber)	20
7.4 Battery Level Indicators (5 Green)	20
7.5 UPS Status Indicators	21
8.0 OPERATION	22
8.1 Startup Checklist for the Liebert GXT3	22
8.2 Initial Startup and Electrical Checks	22
8.3 Manual Battery Test	23
8.4 Put the Liebert GXT3 in Manual Bypass	23

8.5	Shut Down the Liebert GXT3	23
8.6	Disconnecting Input Power from the Liebert GXT3.....	23
8.7	Maintenance Bypass	23
8.8	IT Power System Configuration	24
9.0	COMMUNICATION	25
9.1	Communication Interface Port	25
9.2	Dry Contact.....	25
9.2.1	Any Mode Shutdown	25
9.2.2	Battery Mode Shutdown	26
9.2.3	On Battery	26
9.2.4	Low Battery	26
9.3	Liebert IntelliSlot Communication Cards.....	26
9.3.1	Liebert MultiLink.....	27
9.4	Remote Emergency Power Off.....	27
10.0	MAINTENANCE	28
10.1	Replacing the Internal Battery Pack.....	28
10.1.1	Battery Replacement Procedures	28
10.2	Battery Charging	29
10.3	Precautions	29
10.4	Checking UPS Status.....	30
10.5	Checking UPS Functions	30
11.0	TROUBLESHOOTING	31
11.1	UPS Symptoms.....	31
11.1.1	Indicators	31
11.1.2	Audible Alarm.....	32
11.2	Troubleshooting	32
12.0	SPECIFICATIONS.....	34
12.1	Auto-Learning Battery Run Times	37

FIGURES

Figure 1	Liebert GXT3 5000VA and 6000VA, front view	7
Figure 2	Liebert GXT3, rear view	8
Figure 3	Internal battery pack with connector	9
Figure 4	Power distribution box for GXT3 5000VA and 6000VA models	9
Figure 5	Power distribution box for GXT3 10,000VA model	9
Figure 6	Support bases	11
Figure 7	Remove the front plastic bezel cover	11
Figure 8	Rotate the operation and display panel	12
Figure 9	External battery cabinets connected to 10,000VA Liebert GXT3	14
Figure 10	Power Distribution box removal—captive screws and maintenance bypass breaker	16
Figure 11	Distribution box electrical connections diagram	17
Figure 12	Load level indicators.	20
Figure 13	Battery level indicators.	20
Figure 14	Remove cover from IT Power System Connectors compartment	24
Figure 15	Dry contact pin layout	25
Figure 16	Removing the front plastic bezel cover and battery door	28
Figure 17	Disconnecting the battery plug and battery receptacle (front view)	28
Figure 18	Pulling out the battery packs	29
Figure 19	Battery level indicator	31

TABLES

Table 1	Branch circuit breaker ratings	17
Table 2	Electrical specifications	17
Table 3	UPS status indicators	21
Table 4	Dry contact pin definitions	25
Table 5	Indicator descriptions	31
Table 6	Audible alarm description	32
Table 7	Troubleshooting table	32
Table 8	UPS specifications.	34
Table 9	Operating temperature parameters.	35
Table 10	Power distribution specifications	35
Table 11	External battery cabinet specifications	36
Table 12	Battery run time, minutes, for 5000 and 6000VA UPS models	36
Table 13	Battery run time, minutes, for 10,000VA UPS models.	37

IMPORTANT SAFETY INSTRUCTIONS

SAVE THESE INSTRUCTIONS

This manual contains important safety instructions. Read all safety and operating instructions before operating the uninterruptible power system (UPS). Adhere to all warnings on the unit and in this manual. Follow all operating and user instructions. This equipment can be operated by individuals without previous training.

This product is designed for commercial/industrial use only. It is not intended for use with life support and other designated “critical” devices. Maximum load must not exceed that shown on the UPS rating label. The UPS is designed for data processing equipment. If uncertain, consult your dealer or local Emerson Network Power representative.

This UPS is designed for use on a properly earthed (grounded), 220-240 VAC, 50Hz or 60Hz supply, for installation by qualified personnel. A qualified electrician must review and approve customer supplied wiring, circuit breakers, intended loads and verify correct input, output and earth connections to ensure compliance with technical standards and local electrical codes of practice. Installation instructions and warning notices only for use by qualified personnel are located after the UPS operator instructions in this manual.



WARNING

The battery can present a risk of electrical shock and high short circuit current. The following precautions should be observed before replacing the battery pack:

- Wear rubber gloves and boots
- Remove rings, watches and other metal objects.
- Use tools with insulated handles.
- Do not lay tools or other metal objects on the batteries.
- If the battery kit is damaged in any way or shows signs of leakage, contact your local Emerson representative immediately.
- Do not dispose of batteries in a fire. The batteries may explode.
- Handle, transport and recycle batteries in accordance with local regulations.



WARNING

Although the Liebert GXT3 has been designed and manufactured to ensure personal safety, improper use can result in electrical shock or fire. To ensure safety, observe the following precautions:

- Turn Off and unplug the Liebert GXT3 before cleaning it.
- Clean the UPS with a dry cloth. Do not use liquid or aerosol cleaners.
- Never block or insert any objects into the ventilation holes or other openings of the UPS.
- Do not place the Liebert GXT3 power cord where it might be damaged.

NOTICE

If this UPS is supplied from an “IT” electrical power system, the jumper on the rear panel must be disconnected. See **8.8 - IT Power System Configuration** for details. If connecting to an “IT” system, the installer must provide a 2-pole upstream circuit breaker. Refer to all local and national codes when installing the upstream breaker.

ELECTROMAGNETIC COMPATIBILITY—The Liebert GXT3 complies with the limits of Category C2, pursuant to IEC/EN/AS 62040-2. Operation is subject to the following conditions:

- The output cables shall be no longer than 10m (32ft).
- This device may not cause harmful interference.
- This device must accept any interference received, including interference that may cause undesired operation. Operating this device in a residential area is likely to cause harmful interference that users must correct at their own expense.

The Liebert GXT3 series complies with the requirements of EMC Directive 2004/108/EC and the published technical standards. Continued compliance requires installation in accordance with these instructions and use of accessories approved by Emerson.

NOTICE

This is a product for restricted sales distribution to informed partners. Installation restrictions or additional measures may be needed to prevent radio interference.

Operate the UPS in an indoor environment only in an ambient temperature range of 0-40°C (32-104°F). Install it in a clean environment, free from moisture, flammable liquids, gases and corrosive substances.

This UPS contains no user-serviceable parts except the internal battery pack. The UPS On/Off push buttons do not electrically isolate internal parts. Under no circumstances attempt to gain access internally, due to the risk of electric shock or burn.

Do not continue to use the UPS if the front panel indications are not in accordance with these operating instructions or the UPS performance alters in use. Refer all faults to your dealer.

Servicing of batteries should be performed or supervised by personnel knowledgeable of batteries and the required precautions. Keep unauthorized personnel away from the batteries. Proper disposal of batteries is required. Refer to your local laws and regulations for disposal requirements.

Never block or insert any object into the ventilation holes or other openings.

DO NOT CONNECT equipment that could overload the UPS or demand DC current from the UPS, for example: electric drills, vacuum cleaners, laser printers, hair dryers or any appliance using half-wave rectification.

Storing magnetic media on top of the UPS may result in data loss or corruption.

Turn Off and isolate the UPS before cleaning it. Use only a soft cloth, never liquid or aerosol cleaners.

Information for the Protection of the Environment

UPS SERVICING—This UPS makes use of components dangerous for the environment (electronic cards, electronic components). The components removed must be taken to specialized collection and disposal centers.

NOTICE TO EUROPEAN UNION CUSTOMERS: DISPOSAL OF OLD APPLIANCES—This product has been supplied from an environmentally aware manufacturer that complies with the Waste Electrical and Electronic Equipment (WEEE) Directive 2002/96/CE.







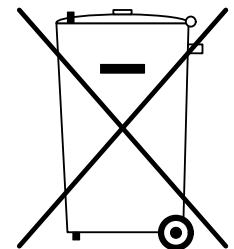





The “crossed-out wheellie bin” symbol at right is placed on this product to encourage you to recycle wherever possible. Please be environmentally responsible and recycle this product through your recycling facility at its end of life. Do not dispose of this product as unsorted municipal waste. Follow local municipal waste ordinances for proper disposal provisions to reduce the environmental impact of waste electrical and electronic equipment (WEEE).

For information regarding the scrapping of this equipment, please browse <http://www.eu.emersonnetworkpower.com> (“Products session” or “Contact us” session) or call our worldwide technical support.

- Toll Free: 00 80011554499
- Toll Number Based in Italy: +39 0298250222

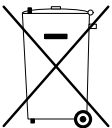

GLOSSARY OF SYMBOLS

	Risk of electrical shock
	Indicates caution followed by important instructions
	AC input
	AC output
	Requests the user to consult the manual
	Indicates the unit contains a valve-regulated lead acid battery
	Recycle
	DC voltage
	Equipment grounding conductor
	Bonded to ground
	AC voltage
	ON/Alarm Silence/Manual Battery Test
	OFF/Bypass
	WEEE

1.0 INTRODUCTION

Congratulations on your choice of the Liebert GXT3 uninterruptible power system (UPS). The Liebert GXT3 comes in nominal power ratings of 5000VA, 6000VA and 10,000VA. It is designed to provide conditioned power to microcomputers and other sensitive electronic equipment.

When it is generated, alternating current is clean and stable. However, during transmission and distribution it may be subject to voltage sags, spikes and complete power failure that may interrupt computer operations, cause data loss and even damage equipment. The Liebert GXT3 protects equipment from these disturbances.

The Liebert GXT3 is a compact, on-line UPS that continuously conditions and regulates its output voltage, whether mains power is present or not. It supplies connected equipment with clean sinewave power. Sensitive electronic equipment operates best from sinewave power.

For ease of use, the Liebert GXT3 features a light-emitting diode (LED) display to indicate both load percentage and battery capacity. It also provides self-diagnostic tests, a combination ON/Alarm Silence/Manual Battery Test button, a Standby/Manual Bypass button and a configuration program.

The Liebert GXT3 has a Liebert IntelliSlot[®] port for communication between the UPS and a network server or other computer systems. This port provides detailed operating information including voltages, currents and alarm status to the host system when used in conjunction with Liebert MultiLink[™]. Liebert MultiLink can also remotely control UPS operation.

2.0 SYSTEM DESCRIPTION

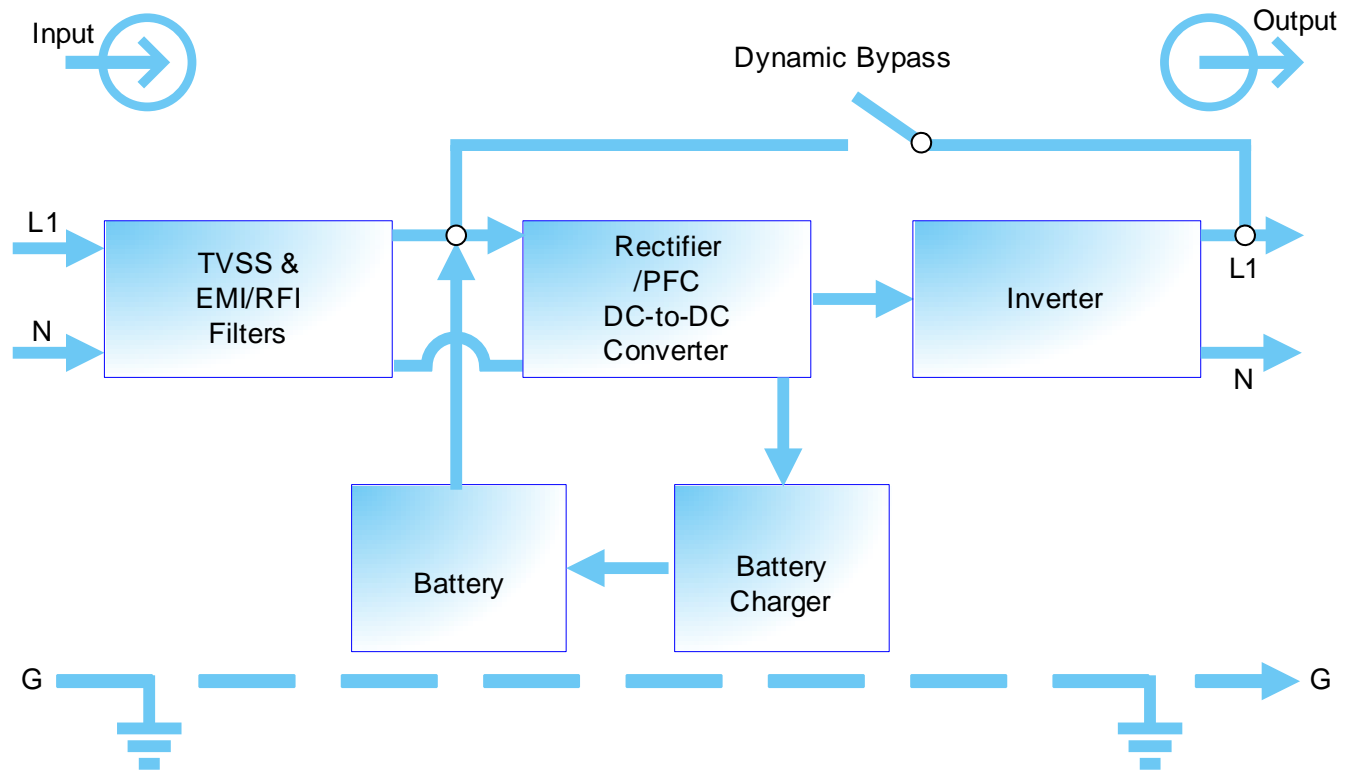

2.1 Transient Voltage Surge Suppression (TVSS) and EMI/RFI Filters

These UPS components provide surge protection and filter both electromagnetic interference (EMI) and radio frequency interference (RFI). They minimize any surges or interference present in the mains line and keep the sensitive equipment protected.

2.2 Rectifier/Power Factor Correction (PFC) Circuit

In normal operation, the rectifier/power factor correction (PFC) circuit converts mains AC power to regulated DC power for use by the inverter while ensuring that the waveshape of the input current used by the UPS is near ideal. Extracting this sinewave input current achieves two objectives:

- The mains power is used as efficiently as possible by the UPS.
- The amount of distortion reflected on the mains is reduced.

This results in cleaner power being available to other devices in the building not being protected by the Liebert GXT3.

2.3 Inverter

In normal operation, the inverter utilizes the DC output of the power factor correction circuit and inverts it into precise, regulated sinewave AC power. Upon a mains power failure, the inverter receives its required energy from the battery through the DC-to-DC converter. In both modes of operation, the UPS inverter is on-line and continuously generating clean, precise, regulated AC output power.

2.4 Battery Charger

The battery charger utilizes energy from the mains power and precisely regulates it to continuously float charge the batteries. The batteries are being charged whenever the Liebert GXT3 is connected to mains power.

2.5 DC-to-DC Converter

The DC-to-DC converter utilizes energy from the battery system and raises the DC voltage to the optimum operating voltage for the inverter. This allows the inverter to operate continuously at its optimum efficiency and voltage, thus increasing reliability.

2.6 Battery

The Liebert GXT3 utilizes valve-regulated, nonspillable, lead acid batteries. To maintain battery design life, operate the UPS in an ambient temperature of 15°C to 25°C (59°F to 77°F). Optional external battery cabinets are available to extend battery run times. For run times, see **Tables 12** and **13**.

2.7 Dynamic Bypass

The Liebert GXT3 provides an alternate path for mains power to the connected load in the unlikely event of a UPS malfunction. Should the UPS have an overload, overtemperature or any other UPS failure condition, the UPS automatically transfers the connected load to bypass. Bypass operation is indicated by an audible alarm and illuminated amber Bypass LED (other LEDs may be illuminated to indicate the diagnosed problem). To manually transfer the connected load from the inverter to bypass, press the Standby/Manual Bypass button once.



NOTE

The bypass power path does NOT protect the connected equipment from disturbances in the mains supply.

3.0 MAJOR COMPONENTS

The Liebert GXT3 is composed of three major assemblies to provide easier handling, installation and versatility.

3.1 Main Frame and Electronics

The cabinet is shipped with internal batteries installed and a basic, hardwire distribution box attached and ready to install.

Figure 1 Liebert GXT3 5000VA and 6000VA, front view

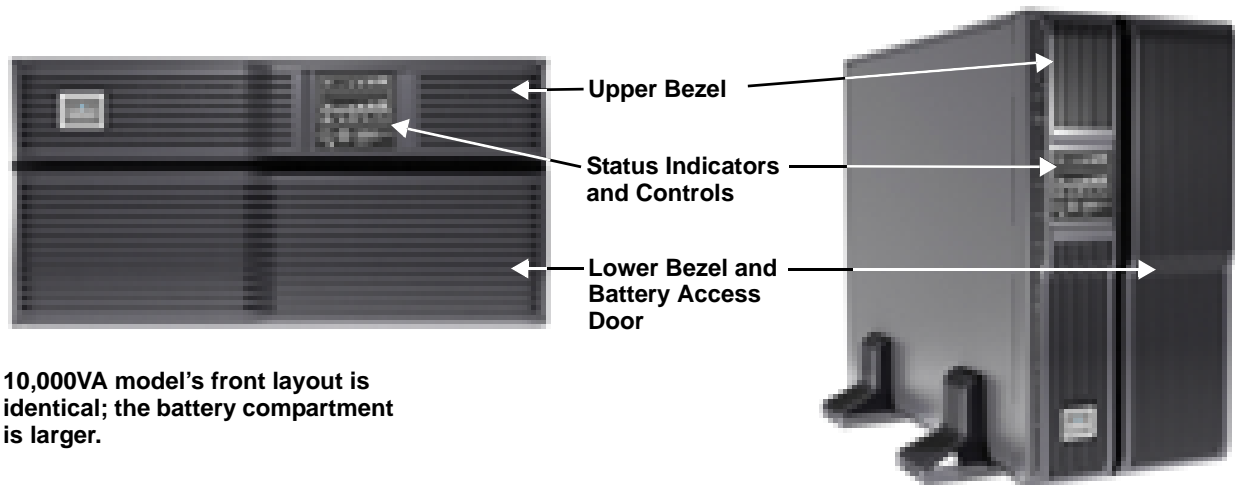
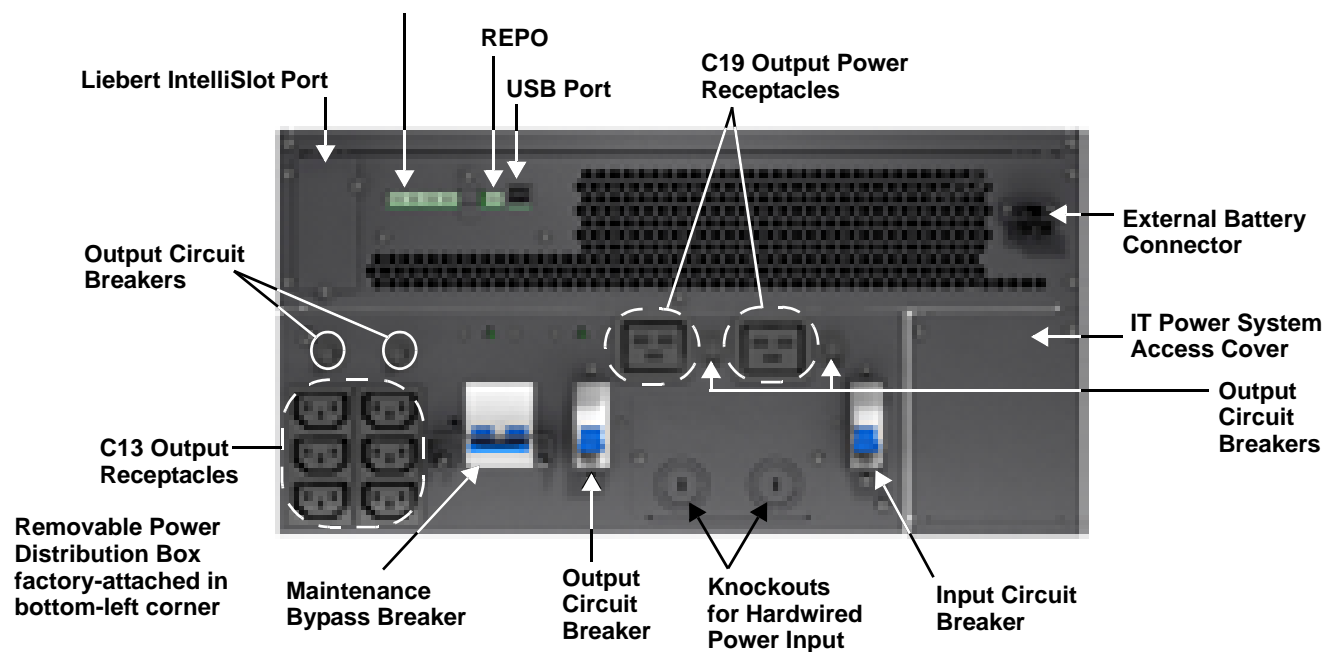
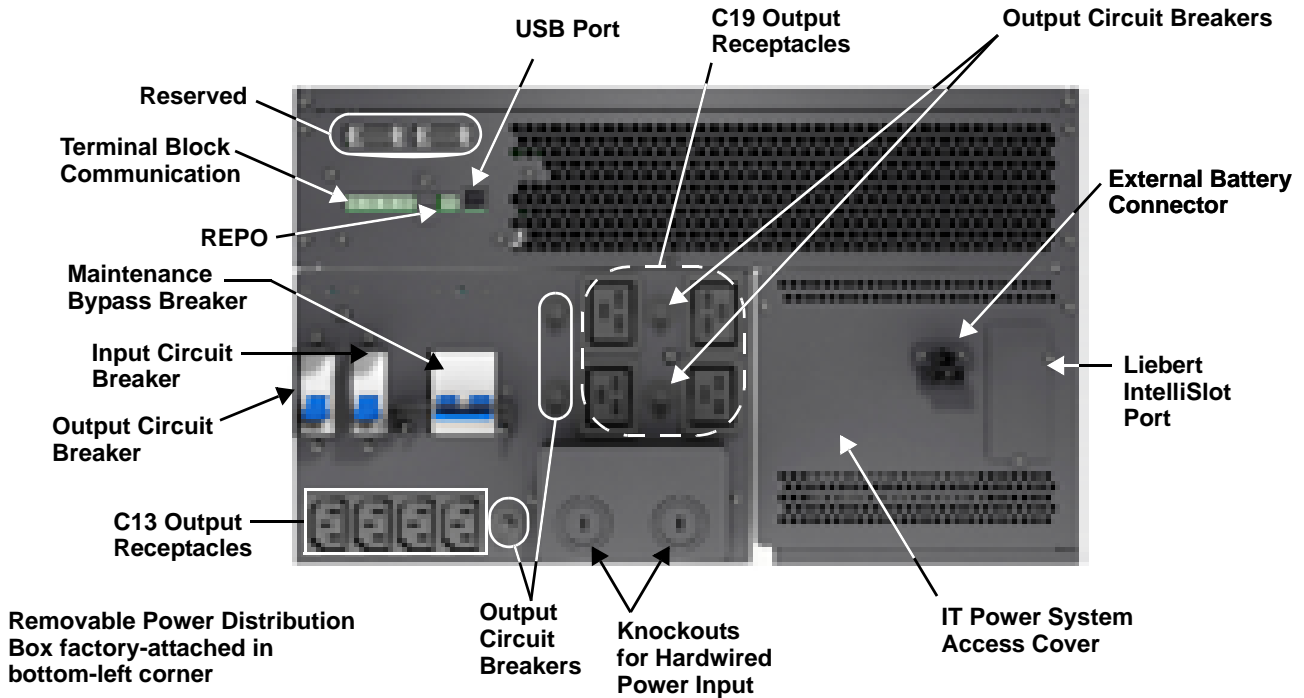

Figure 2 Liebert GXT3, rear view

Liebert GXT3, 5,000 & 6000VA Terminal Block Communication



LiebertGXT3, 10,000VA



3.2 Internal Battery Packs

The UPS has two internal battery packs behind a battery access door on the front of the unit. Each internal battery pack is fitted with a connector to link to the UPS.

Figure 3 Internal battery pack with connector

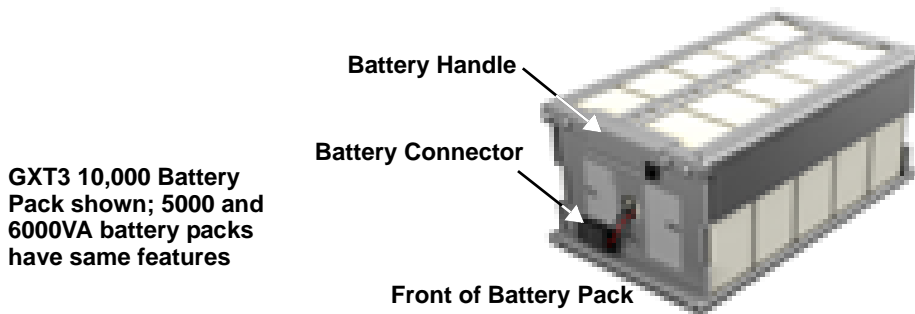

3.3 Removable Power Distribution Box

The UPS arrives with a power distribution pack installed. This box always contains the UPS input circuit breaker.

Figure 4 Power distribution box for GXT3 5000VA and 6000VA models

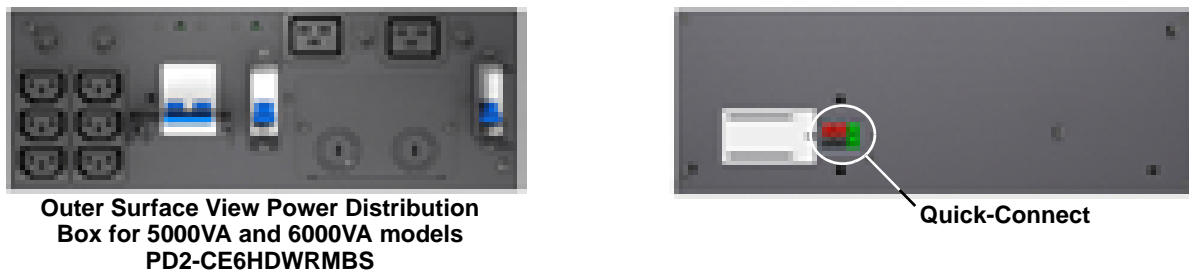
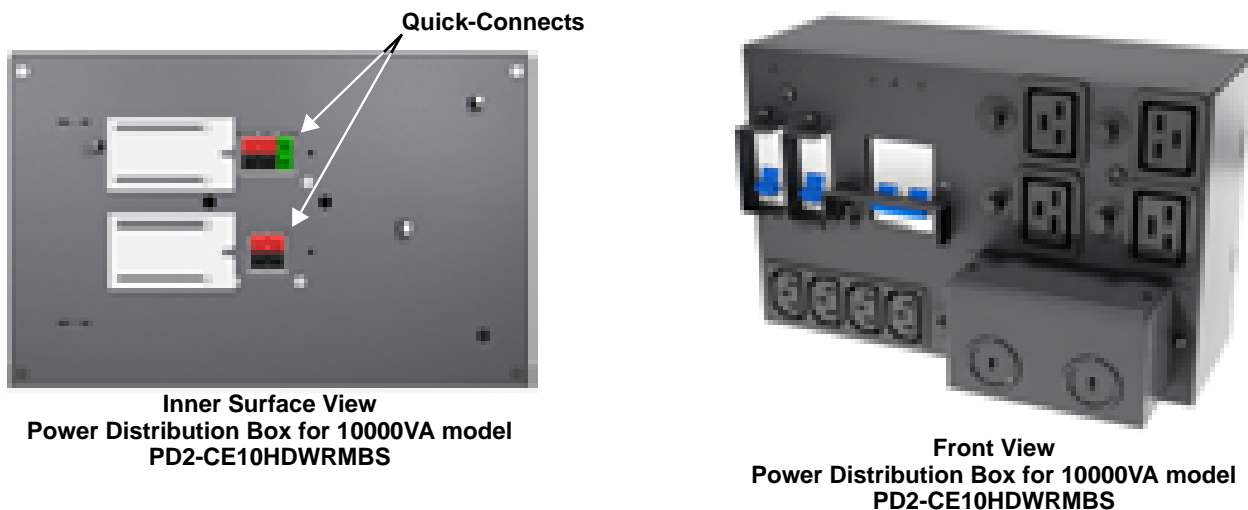

Figure 5 Power distribution box for GXT3 10,000VA model



NOTE

Hardwire and hardwire/receptacle boxes that include a manual bypass switch allow AC power to continue to flow from the mains input to the load while the box is removed from the UPS. For details, refer to 5.3 - Connect Input/Output Power.

4.0 WHAT'S INCLUDED

The Liebert GXT3 is shipped with the following items:

- User Manual
- Compact Disk with
 - Liebert MultiLink
 - Configuration program
 - User manual (electronic version)
- USB cable, one; 2m (6-1/2 ft.) long
- Mounting hardware, including screws and handles
- Power Distribution Box, installed on Liebert GXT3
- Support base set, one
- Warnings, Safety Instructions booklet and WEEE recycling sheet (ISO 14001 compliance)



NOTE

The GXT3 External Battery Cabinet shipping package includes one battery cabinet, two spacers for tower configuration and one DC power cable.

5.0 INSTALLATION AND CONFIGURATION

Do NOT attempt to start the UPS, turn on any circuit breaker or energize the input power until instructed to do so in **8.2 - Initial Startup and Electrical Checks**.

Visually inspect the UPS for freight damage. Report any damage to the carrier and your local dealer or Liebert representative.



CAUTION

The UPS is heavy (see **12.0 - Specifications**). Take proper precautions when lifting or moving it.

Install the Liebert GXT3 indoors in a controlled environment, where it cannot be accidentally turned off. Place it where air flows unrestricted around the unit. The installation location must be free of water, flammable liquids, gases, corrosives and conductive contaminants. Maintain a minimum clearance of 100mm (4 inches) in the front and rear of the UPS. Maintain an ambient temperature range of 0 to 40°C (32 -104°F) without derating.



NOTE

UPS operation in sustained temperatures outside the range of 15-25°C (59°-77°F) reduces battery life.

5.1 Install the Main Cabinet

The Liebert GXT3 may be installed in either a tower configuration or in a rack, depending on available space and use considerations. Determine the type of installation and follow the appropriate instructions in either **5.1.1 - Tower UPS Installation** or **5.1.2 - Rack-Mount UPS Installation**.

5.1.1 Tower UPS Installation

To install the Liebert GXT3 as a tower:

1. Take out support bases from the accessories bag (see **Figure 6**).

Figure 6 Support bases

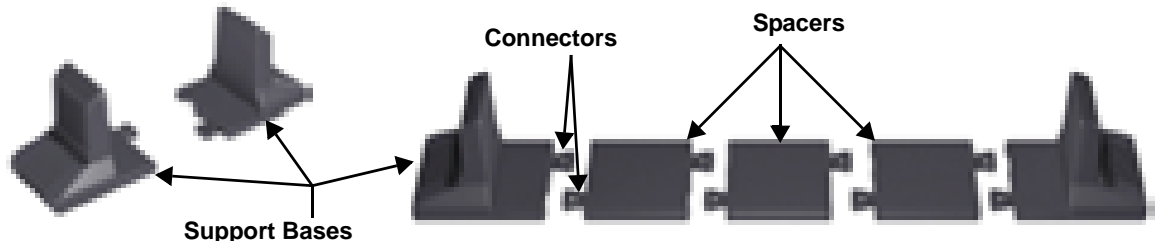

2. If optional Liebert external battery cabinets will be connected to the Liebert GXT3, take out the spacers shipped with the battery cabinet.
3. Connect the spacers and the support bases as shown in **Figure 6**. Each Liebert GXT3 needs two assembled support bases, one in the front and one in the rear.
4. Adjust the direction of the operation and display panel and logo on the Liebert GXT3.
 - a. Remove the front plastic bezel cover as shown in **Figure 7**.

Figure 7 Remove the front plastic bezel cover

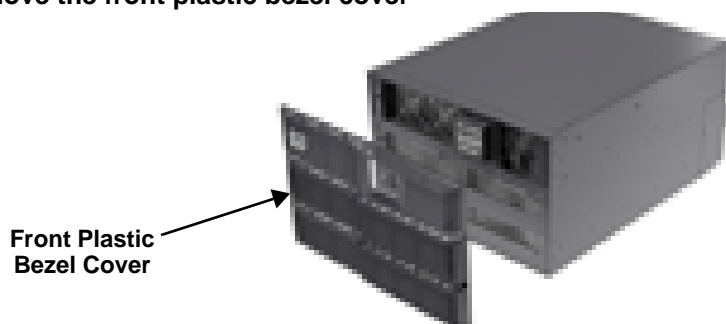

- b. Pull the operation and display panel gently, rotate it 90 degrees clockwise and snap it back into position, as shown in **Figure 8**.

Figure 8 Rotate the operation and display panel

Operation and Display Panel Rotated Clockwise 90 Degrees

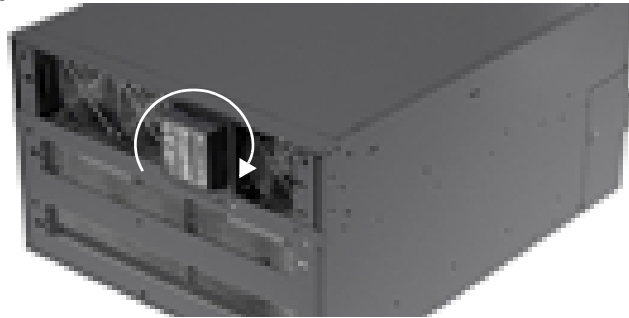

- c. Pull the logo on the front plastic bezel cover gently, rotate it 90 degrees clockwise and snap it back into position. The rotated front plastic bezel cover is shown in **Figure 8**.
 - d. Replace the front plastic bezel cover on the Liebert GXT3. At this point, the UPS operation and display panel and logo have been rotated 90 degrees clockwise, which provides upright viewing for users.
5. Place the Liebert GXT3 and any battery cabinets on the support bases. Each Liebert GXT3 needs two support assemblies, as shown in the lower half of **Figure 1**.

5.1.2 Rack-Mount UPS Installation

When using the Liebert GXT3 in a rack-mount configuration, the UPS must be supported by a slide kit, fixed rails or a shelf.

When using the optional Adjustable Rack Mount Kit, you will use the following instructions. The figures accompanying **5.1.3 - Installing the Adjustable Rack-Mount Kit—Sold Separately** shows the positioning of the rack-mounting brackets. Liebert recommends taking the internal batteries out of the UPS during rack installation. This will make the UPS cabinet lighter and easier to handle.



CAUTION

The GXT3 is heavy; see **12.0 - Specifications**. The UPS must be installed as near the bottom of a rack as possible. If placed too high, it can make the rack top-heavy and prone to tipping over.

5.1.3 Installing the Adjustable Rack-Mount Kit—Sold Separately

This kit contains parts needed to mount several different models of UPS and external battery cabinets into EIA310-D standard four-post racks that are 18-32" deep (457-813mm). The weight limit per pair of adjustable rack-mounting brackets is 91 kg (200lb).

Parts included are:

Item	Quantity
Rear bracket members	2
Front bracket members	2
Inner bracket members	2
M4 machine screws	16
M4 locking hex nuts	8
M5 machine screws	8

Tools needed for installation are:

- one Phillips screwdriver
- one 7mm wrench

The adjustable rack-mounting brackets (Part#: RMKIT18-32) feature retaining latches to prevent users from inadvertently sliding the UPS or battery cabinet out of the rack.

To install the rack mount brackets:

1. Unpack two (2) rack-mounting bracket assemblies and mounting hardware from this kit. Bracket assemblies are interchangeable between left-hand or right-hand.
Remove inner member of each bracket assembly as shown at right by extending it to its outermost position, depressing the retaining latch and then pulling the inner member out of the bracket assembly.
2. Determine the height position inside the rack enclosure where you want to mount the UPS or battery cabinet.

CAUTION

Reduce the risk of tipping the rack enclosure by placing the UPS or battery cabinet in the lowest possible rack position.

3. Install the rear member of each bracket assembly into the rack enclosure with two (2) M5 screws provided in this kit (see figure at right). The return flanges on the bracket assembly fit to the inside of rack mounting rails. Insert screws loosely (finger-tight) into the top and bottom holes of the return flange on the rear member. Extend the bracket assembly by sliding the front member forward until it touches the front rack mounting rail. Insert two (2) M5 screws loosely (finger-tight) into the top and bottom holes of the return flange on each front member. Make sure that the bracket assemblies are at the same mounting height on all four (4) rack mounting rails.
4. Get eight (8) M4 screws and eight (8) M4 nuts from the hardware pack in this kit. Each nut has a locking, nylon insert that begins gripping the screw when it is halfway tight. Make sure to tighten the nut and screw completely to ensure locking action. Fasten the rear member and the front member together using (4) screws and (4) nuts per bracket assembly as shown in at right. For maximum support, insert fasteners for each bracket assembly as far apart as possible, depending on rack depth, while still joining both members (see figures at right). Check alignment of bracket assemblies and **TIGHTEN ALL SCREWS FROM Steps 2 and 3.**
5. Prepare the UPS or battery cabinet (the “equipment”) for rack mounting by following instructions in the equipment’s user manual. The equipment may require additional parts to be added or parts to be removed for rack mounting. After it is prepared, lay the equipment in rack-mounting position. Fasten the inner members from **Step 1** to the equipment on both sides as shown at right with eight (8) M4 screws provided in the kit. Make sure retaining latch is near the rear of the equipment as shown (see figure at right).

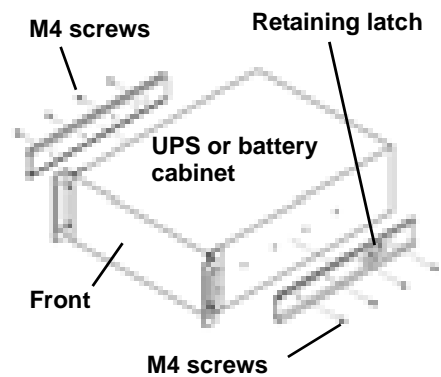
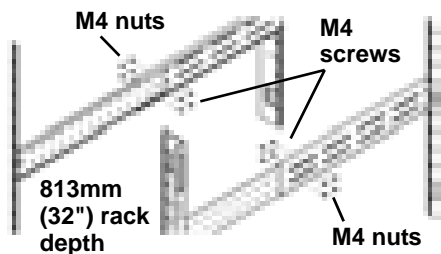
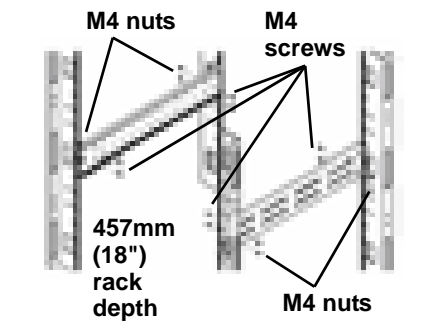
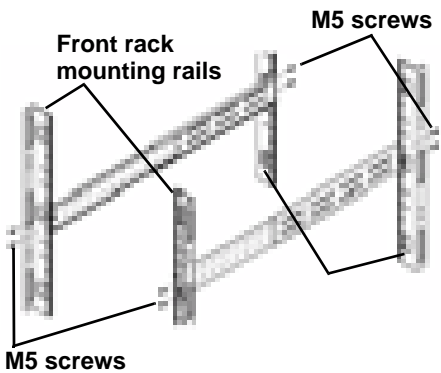
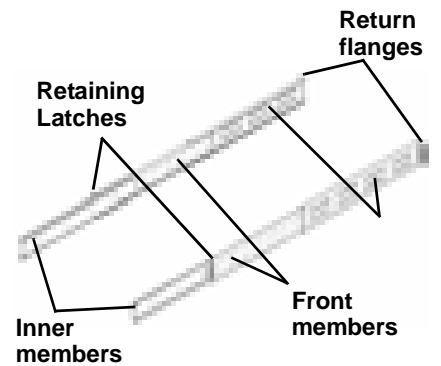

- If available, apply a bead of grease 25mm (1") long at four (4) places inside the bottom, curved tracks of the front members as shown below right. The grease will allow the equipment to slide into the bracket assemblies more easily.

CAUTION

Lifting equipment into the rack may be a two-person job, depending on the weight of the equipment. Liebert recommends taking the internal batteries out of the UPS during rack installation. This will make the UPS cabinet lighter and easier to handle. For the weight of the UPS, see **Table 8**; for the battery cabinet's weight, see **Table 11**.

- Insert the equipment, with inner members attached in **Step 5**, into the bracket assemblies by inserting the top and bottom edges of the inner members into the top and bottom curved tracks of the front members and sliding the equipment into the rack (see figure at right). Ends of inner members are tapered to allow the rear of the equipment to be angled upward before insertion, if space allows.

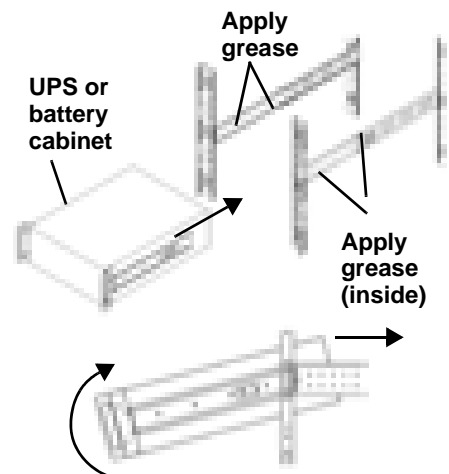

Insert the UPS into the front members, lift the front and push it into the rack..

Then the rear, bottom edges of the inner members can be placed into the front edge of the bottom tracks and the front of the equipment can be tipped up so they are level to insert the top edges of the inner members before sliding the equipment into the rack (see figure below right). The equipment should move smoothly into the bracket assemblies. If it does not, recheck the alignment of the front and rear members from **Steps 2** and **3**.

- Secure the front of the equipment to the rack mounting rails to prevent the equipment from sliding out of position. If securing holes are provided on the front of the equipment that align with the center holes on the return flange of the front members, you can use the four (4) extra M5 screws provided in the kit to secure the equipment. Otherwise, the equipment should be secured to the front of the rack with four (4) customer-supplied fasteners.

5.2 External Battery Cabinet Installation

Optional Liebert external battery cabinets may be connected to the UPS to provide additional battery run time. External battery cabinets are designed to be placed on one side of the UPS or stacked beneath the UPS. External battery cabinets can be used in either a rack-mount or tower configuration.

CAUTION

The external battery cabinet(s) are heavy (see **12.0 - Specifications**). Take proper precautions when lifting them.

Figure 9 External battery cabinets connected to 10,000VA Liebert GXT3

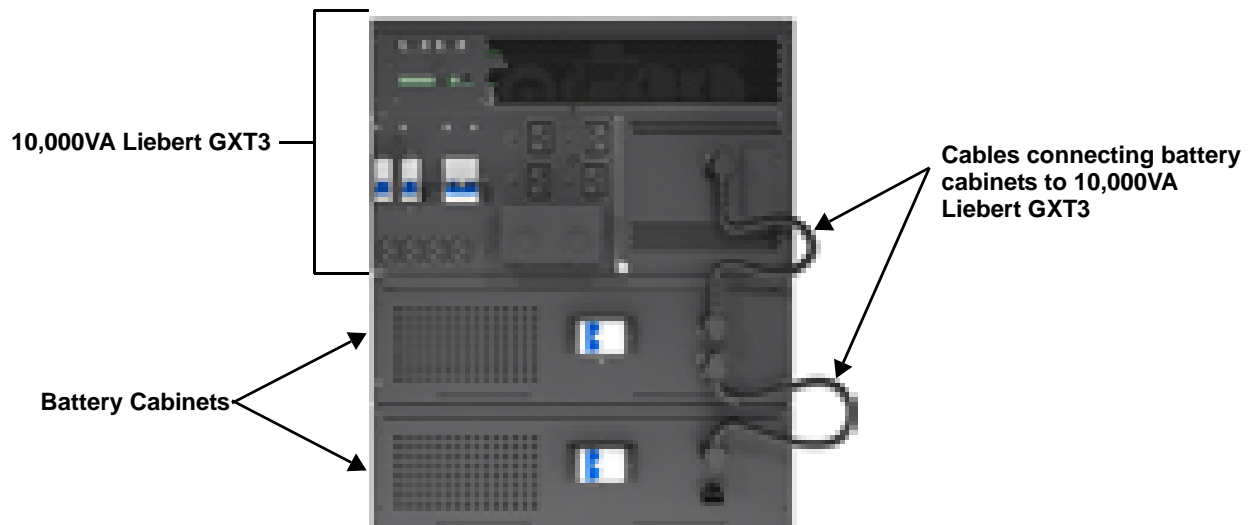

1. Visually inspect the external battery cabinet for freight damage. Report damage to the carrier and your local dealer or Liebert representative.
2. For slide rail installations, first remove the top/side fin. Top/side fin slides forward and then lift up to remove. Optional rack-mount handles are shipped with the external battery cabinet and may be installed at this time if desired.
3. Securing hardware and slide rails are sold separately. Please contact your local dealer or Liebert representative for these additional options and any assistance needed. Fasten the slides into position with the screws per the instructions included with the slide rails.
4. Use the enclosed support bases for the tower option to prevent tip-over. One additional set of support base extensions ships with each external battery cabinet.
5. Put the UPS in Bypass Mode by pressing the bypass button on the front of the unit one time.
6. Verify the External Battery Cabinet breaker is in the Off position.
7. Connect the supplied external battery cabinet cable to the rear of the external battery cabinet, then to the rear of the UPS.
8. Turn the External Battery Cabinet breaker to the On position.
9. Press the On button on the front of the UPS for 4 seconds to return the unit to inverter Mode.
10. Verify the circuit breaker on the External Battery Cabinet is in the On position.
11. Use the included configuration program to program the UPS for the number of external battery cabinets connected. Instructions for the configuration program are in **6.0 - Configuration Program**.
12. The UPS is now equipped with additional backup battery run time. For approximate battery run times, refer to **Tables 12 and 13**.



NOTE

When removing the External Battery Cabinet, the circuit breaker on the rear of the cabinet must be turned off before disconnecting the cable.



NOTE

If the UPS is to be shipped or stored for an extended time, the connector should be disconnected. This will minimize any standby current drain on the batteries and help attain their design life.

5.3 Connect Input/Output Power

Figure 10 Power Distribution box removal—captive screws and maintenance bypass breaker

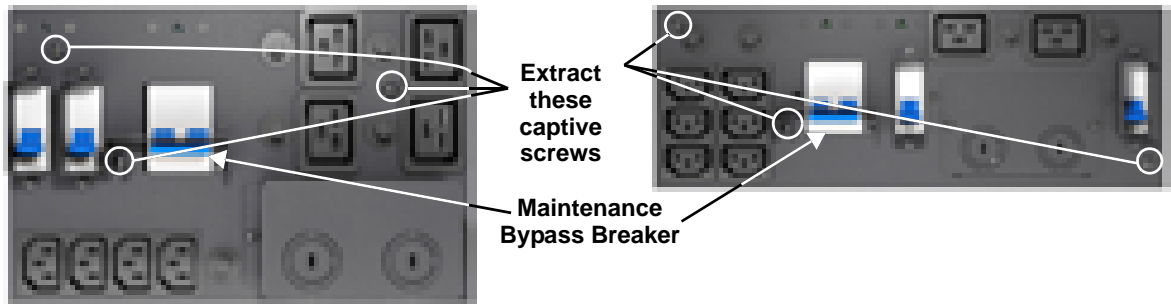

The UPS should arrive with the power distribution box attached. If the box needs to be removed for maintenance or replacement, follow these instructions to remove and install the power distribution pack.

To remove:

1. Ensure maintenance bypass lamp is on. To place the unit in maintenance bypass, see **8.4 - Put the Liebert GXT3 in Manual Bypass**.
2. Loosen one captive screw over the maintenance bypass breaker.
3. Turn the maintenance bypass breaker on.

NOTICE

The load is unprotected from disturbances in the power supply while the UPS is on bypass.

4. Turn the output and input breaker off.
5. Loosen other captive screws until the power distribution box releases.
6. Remove the power distribution box from the UPS and set it aside.
7. Loosen screws over the plastic cover for the connector on the rear of the panel.
8. Slide plastic cover over connector and tighten screws.



NOTE

Do not operate the UPS with this box removed. To disconnect all power to this box and load, the utility input power also must be disconnected.

To install:

1. Align connectors and press box onto UPS
2. Hold box firmly against UPS and tighten captive screws except one over the maintenance bypass breaker.
3. Turn the output and input breaker on.
4. Start the UPS according to startup instructions.
5. Verify that the UPS lamp is illuminated.
6. Turn the maintenance bypass breaker off.
7. Insert the maintenance bypass cover behind the captive screw and tighten the screw.



NOTE

The maintenance bypass breaker cover must be installed behind the captive screw and the screw must be tightened for the UPS to operate in inverter mode.

5.3.1 Distribution Box Electrical Connections

Electrical connections are made through a removable power distribution box that attaches to the rear of the UPS.

- PD2-CE6HDWRMBS fits the 5000 and 6000VA models of the Liebert GXT3
- PD2-CE10HDWRMBS fits the 10,000VA model of the Liebert GXT3

The installer must provide an upstream branch circuit breaker. The input circuit breaker on the distribution box and the output circuit breaker on the rear of the power distribution box disconnect all power between the main cabinet and the distribution box.

Models equipped with a manual bypass breaker pass bypass power directly to the bypass breaker from the input terminal block. The input circuit breaker on the distribution box does not disconnect power from the manual bypass breaker.

Table 1 Branch circuit breaker ratings

Unit Rating	Maximum Breaker Rating
5000VA	D Type 32A
6000VA	D Type 32A
10,000VA	D Type 63A

Figure 11 Distribution box electrical connections diagram

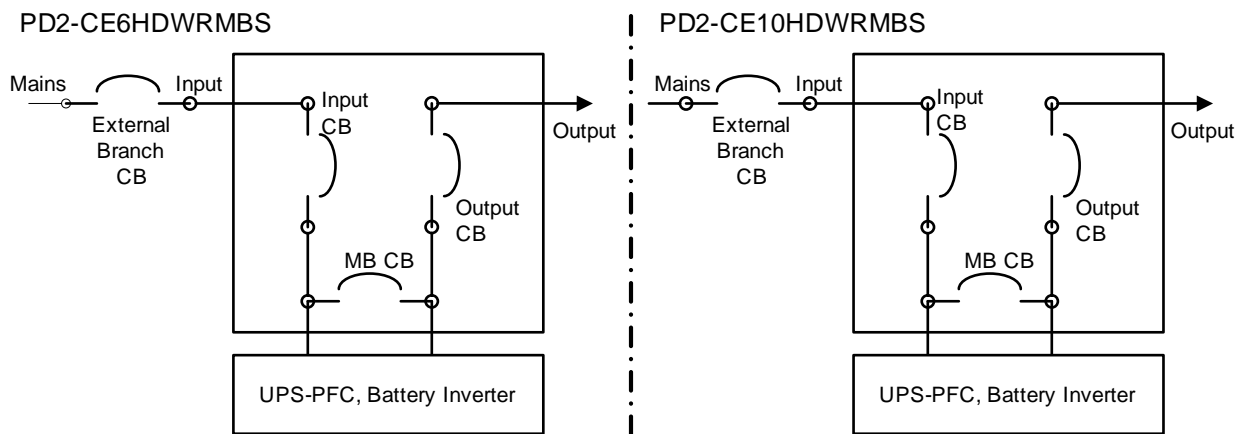

PD2-CE6HDWRMBS and PD2-CE10HDWRMBS Terminal Block Connections

Conduit entry holes are provided on the rear and side of the box. Input and output wiring should not share the same conduit. Emerson recommends using strain relief when installing the wire.

Table 2 Electrical specifications

UPS Model	Recommended (Maximum) External Overcurrent Protection	Recommended Wire (Including ground wire) (75°C copper wire)	Maximum Wire Accepted by Terminal Block	Terminal Tightening Torque
GXT3-5000RT230 GXT3-6000RT230	32A	4mm ² (10AWG)	6mm ² (8AWG)	2.26 Nm (20 in-lb)
GXT3-10000RT230	63A	10mm ² (6AWG)	16mm ² (4AWG)	

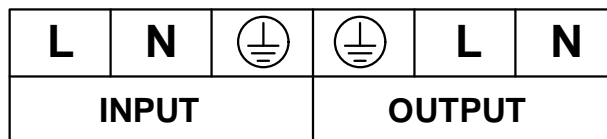

NOTE

The installer must provide circuit breaker protection according to local codes. The mains disconnect should be within sight of the UPS or have appropriate an appropriate lock-out. Maintain service space around the UPS or use flexible conduit.

The installer must provide output distribution panels, circuit breaker protection or emergency disconnects according to local codes. Output circuits must not share a common conduit with any other wiring.

6.0 CONFIGURATION PROGRAM

The final step of installation may require custom configuration of your UPS using the enclosed configuration program. Some configuration settings may be changed only while the UPS is off. These should be set before the UPS is put into full-time service powering the critical load.

For most users operating with 230VAC and with no external batteries, the factory default settings will be adequate.

6.1 Configuration Program Features

- Select L-N output voltages to match local voltages.
- Enable/Disable Auto-Restart.
- Select frequency converter operation with a fixed output frequency of 50 or 60 Hz.
- Set the Low Battery Warning alarm time from 2 to 30 minutes.
- Enable/Disable the Auto-Battery test.
- Set the Auto-Battery test to 7, 14, 21 or 28 days.
- Specify the number of external battery cabinets connected to the UPS to adjust the remaining run time calculations reported by Liebert software products.
- Modify the shutdown setting of the terminal block (for information on pin assignments, see **Table 2**).

6.1.1 What You Will Need

In addition to the Liebert GXT3 UPS, you will need the configuration program CD and USB cable included in the UPS accessory box. A Windows 95® or later computer, desktop or laptop, is also required to set up and run the configuration program.

7.0 CONTROLS AND INDICATORS

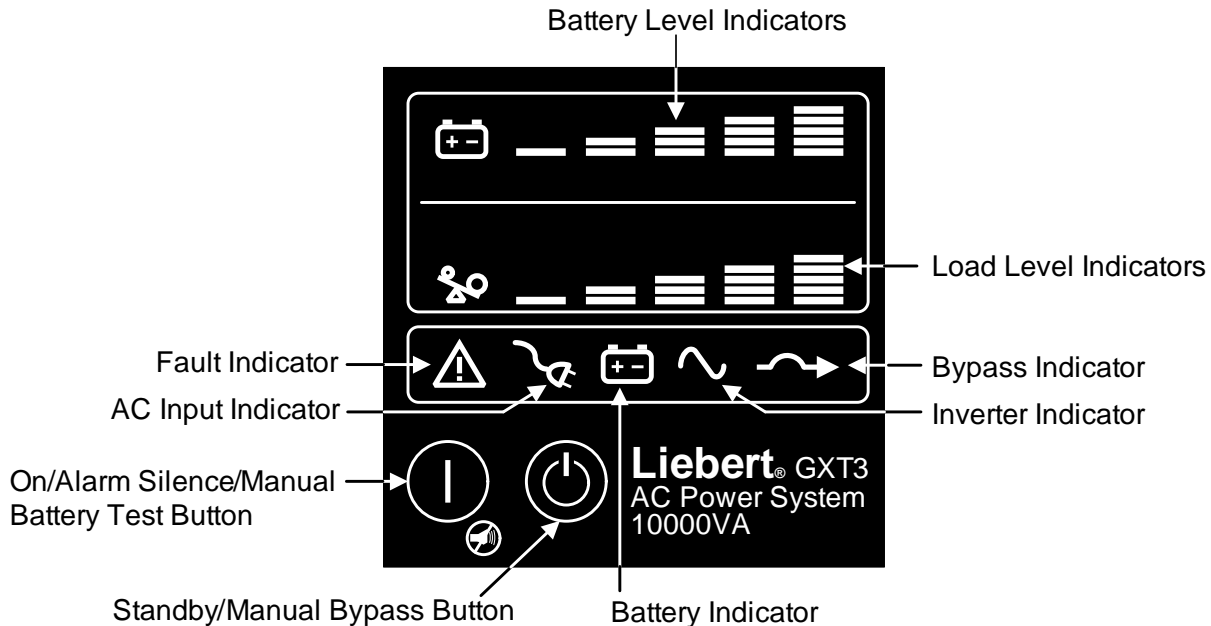

7.1 ON/Alarm Silence/Manual Battery Test Button

This button controls output power to connected load(s) and has three functions:

- ON
- Alarm Silence
- Manual Battery Test

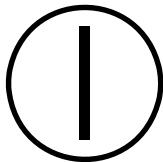

ON - Pressing this button for four seconds will start the UPS.

Alarm Silence - To silence alarms, press this button for at least one second. After the alarm is silenced, the Liebert GXT3 will reactivate the alarm system to alert of additional problems.



NOTE

The LOW BATTERY and BYPASS reminder alarms CANNOT be silenced.

Manual Battery Test - To initiate a manual battery test, press the ON button for at least one second while operating from mains power with no alarm conditions present.

- If only three of the five Battery LEDs illuminate, allow the UPS to recharge the batteries for 24 hours.
- After 24 hours, retest the batteries.
- After the batteries have been retested, if only three of the five Battery LEDs illuminate, contact your local dealer, Emerson representative or Emerson Channel Support.

7.2 Standby/Manual Bypass Button

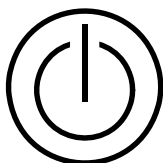

This button controls output power to connected load(s) and has dual functions: Standby and Manual Bypass.

NOTICE

Pressing the Standby/Manual Bypass button once will transfer the load to bypass power and the load will be unprotected from disturbances in utility supply. Pressing the Standby/Manual Bypass button twice within 4 seconds while on Bypass will cut off power to the output sockets and connected loads. Perform all necessary shutdown procedures on connected loads before pressing this button twice.

7.3 Load Level Indicators (4 Green, 1 Amber)

The load level indicator is composed of five sets of LED bars that illuminate to indicate the relative load on the UPS output in 25% increments ($\pm 5\%$). The load level indicator will illuminate as shown in **Figure 12**.

The load level indicators display the approximate electrical load placed upon the UPS at all times.

Figure 12 Load level indicators.

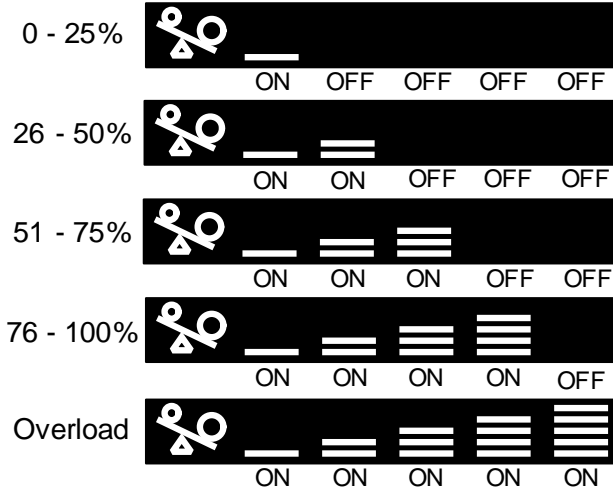

7.4 Battery Level Indicators (5 Green)

The battery level indicator is composed of five sets of LED bars that illuminate and flash to indicate the battery capacity level. The Liebert GXT3 battery capacity level is shown in 20% increments ($\pm 5\%$). The battery level indicators will illuminate as shown in **Figure 13**.

The battery level indicators display approximate battery capacity at all times.

The Liebert GXT3 is equipped with automatic and remote battery test features. The default setting is for the automatic test to occur every 14 days (this option is user-configurable) if mains has not been interrupted. Should the battery fail this test, the red Fault indicator LED along with the A and C diagnostic LEDs will illuminate and an alarm will sound (refer to **11.0 - Troubleshooting**). The remote test feature functions with Liebert MultiLink and can remotely initiate the battery test.



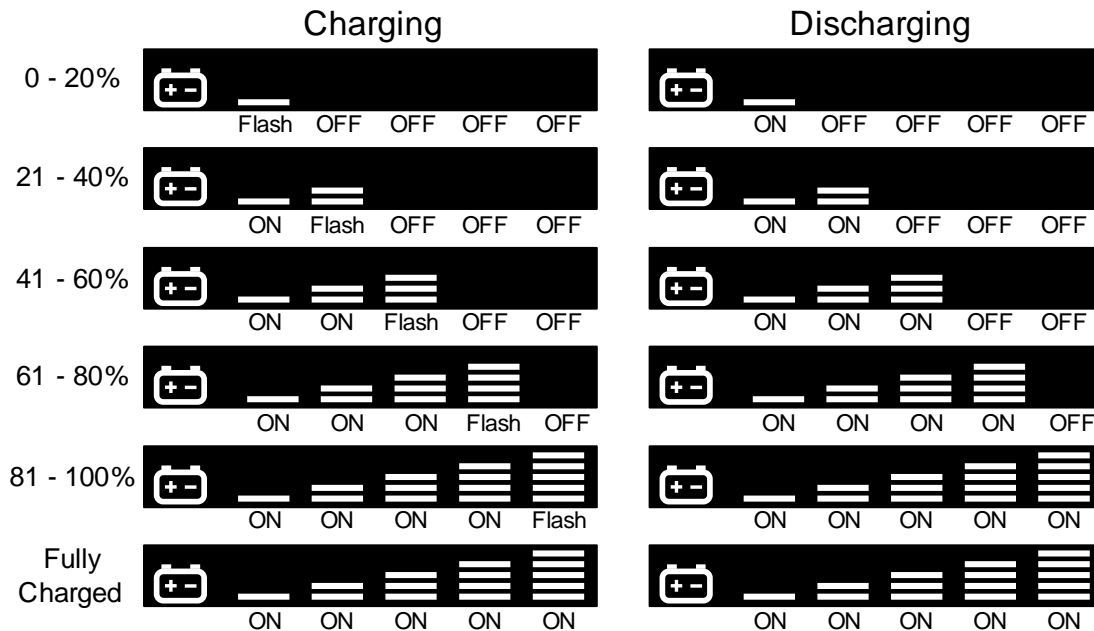

Figure 13 Battery level indicators.



7.5 UPS Status Indicators

UPS status is indicated by five symbols: fault indicator, AC input indicator, battery indicator, inverter indicator and bypass indicator. **Table 3** shows the symbols and their meanings.

Table 3 UPS status indicators

UPS Status Indicator	Icon	Color	Description
Fault Indicator		Red	On if the UPS has detected a fault; Off if there is no fault
AC input Indicator		Green	On when the mains input power is normal; Off during mains failure
Battery Indicator		Amber	On when the battery is supplying power; Off when the battery is not supplying power
Inverter Indicator		Green	On when the inverter is supplying power; Off when the inverter is not supplying power
Bypass Indicator		Amber	On when the bypass is supplying power; Off when the bypass is not supplying power; flashing when mains power is outside specifications

8.0 OPERATION

This section describes checks to be made before starting the UPS, how to start the UPS, manual battery test, manual bypass, shutting down the UPS and disconnecting the mains power from the UPS.



NOTE

The Liebert GXT3's battery has been fully charged before delivery, but some charge will be lost during storage and shipping. To ensure that the battery has adequate reserve power to protect the connected load, charge the battery for three hours before putting the UPS into service.

8.1 Startup Checklist for the Liebert GXT3

Before starting the UPS, perform these checks:

- ___ 1. Check that the input plugs and loads are connected properly and reliably.
- ___ 2. Check that the battery cable is connected properly.
- ___ 3. Check that the communication cables are connected properly.

8.2 Initial Startup and Electrical Checks

1. Verify that the Input Output circuit breakers are off.
2. During initial system checks, disconnect all loads (open load disconnects).
3. Inspect all wiring, cables and connection.
4. If external battery cabinets are used, verify that the battery interconnect cables are fully inserted in the sockets.
5. Place the manual bypass breaker in BYPASS position.
6. Turn on the branch circuit disconnect to apply voltage to the input terminal block.
7. Using a voltmeter, verify the expected L1-N voltage.
Verify that the same voltages appear at the Output terminals. The Bypass lamp by the switch will light.
8. After verifying proper input voltage to the UPS terminal block, turn off the branch circuit power, close all access panels to the distribution box and reapply input power.
9. Close the Input circuit breaker located on the distribution box. The green AC INPUT lamp should illuminate on the front panel.
10. Press the ON button for four seconds. After several seconds, the UPS ON lamp will turn on continuously. If the batteries are determined to be charged above 80%, an automatic battery test will run for about 15 seconds.
11. Close the Output circuit breaker on the rear of the power distribution box. The light by the input breaker will illuminate.
12. Return the manual breaker to the Inverter position. The output terminal block will be powered at this time.
13. Connect all loads for normal operation.

8.3 Manual Battery Test

To initiate a manual battery test, press the On/Alarm Silence/Manual Battery Test button for at least half a second while operating from mains power with no alarm conditions present.

- If only the first two of the five LED segments illuminate, allow the UPS to recharge the batteries for 24 hours.
- Retest the batteries after 24 hours of charging.
- After the batteries have been retested, if only two of the five Battery LEDs illuminate, contact your local Emerson representative or Emerson Network Power Channel Support.
- If none of the five Battery LEDs illuminate during a manual battery test, check the battery connection and allow the UPS to recharge the batteries for 1 hour, then initiate a manual battery test again.
- If none of the five Battery LEDs illuminate during the second manual battery test, replace batteries and contact your local Emerson representative or Emerson Channel Support.

8.4 Put the Liebert GXT3 in Manual Bypass

Press the Standby/Manual Bypass button once while the UPS is in Mains (AC) Mode. The UPS will transfer the connected loads to the internal bypass. If the internal bypass is not available because of mains power problems, pressing this button once will be ignored. Bypass operation is indicated by an audible alarm and illuminated amber Bypass indicator. (If other indicators are illuminated, refer to 11.0 - Troubleshooting.)

8.5 Shut Down the Liebert GXT3

1. Transfer the UPS to manual bypass by pressing the Standby/Manual Bypass button once.
If manual bypass is not available, disregard the first step.
2. Press the Standby/Manual Bypass button twice within four seconds to shut down the UPS.

Power to the connected loads is now Off.

8.6 Disconnecting Input Power from the Liebert GXT3

1. After the UPS has been shut down as detailed in 8.5 - Shut Down the Liebert GXT3, turn off the Output Circuit Breaker.
2. Wait 30 seconds and verify that all indicators have turned Off and the fan has stopped; this indicates that the power-off is complete.
3. Turn the external battery cabinet breaker switch to the Off position if the UPS has an external battery cabinet.

After powering off the UPS, the UPS ceases output and the load is powered Off.

8.7 Maintenance Bypass

Maintenance Bypass Mode is used when maintenance or replacement is required. To place the unit in Maintenance Bypass:

1. Place the UPS on internal bypass. This may be done by either of the following methods:
 - a. Press the Off button on the front panel one time.
 - b. Slide the bracket away from the manual bypass breaker on the rear of the UPS. This requires loosening the captive screw and sliding the bracket up and away from the Manual Bypass Breaker.
2. Move the Manual Bypass Breaker on the rear of the UPS to the bypass position. This requires loosening the captive screw and sliding the bracket up and away from the manual bypass breaker.

8.8 IT Power System Configuration

1. Remove screws on the IT Power System Access Cover as shown in **Figure 14**.
2. Disconnect the connectors as shown in figure.
3. Install IT Power System Access Cover and screws.

Figure 14 Remove cover from IT Power System Connectors compartment

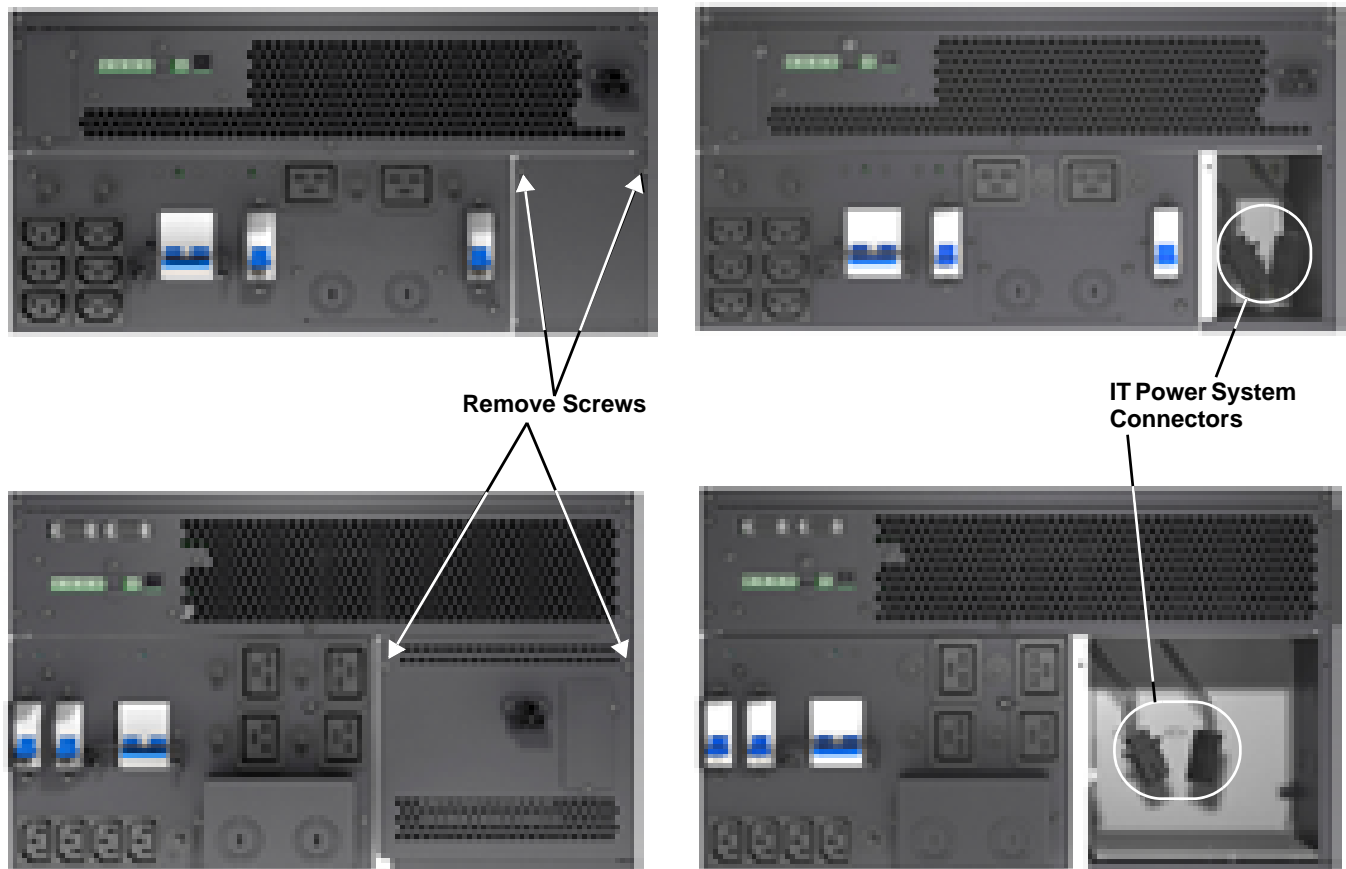

9.0 COMMUNICATION

9.1 Communication Interface Port

The Liebert GXT3 UPS has a terminal block on the rear of the UPS unit. Several signals are provided on this port and are assigned as follows.

9.2 Dry Contact

The Dry Contact includes eight pins, as shown in **Figure 15**. Their definitions are listed in **Table 4**.

Figure 15 Dry contact pin layout

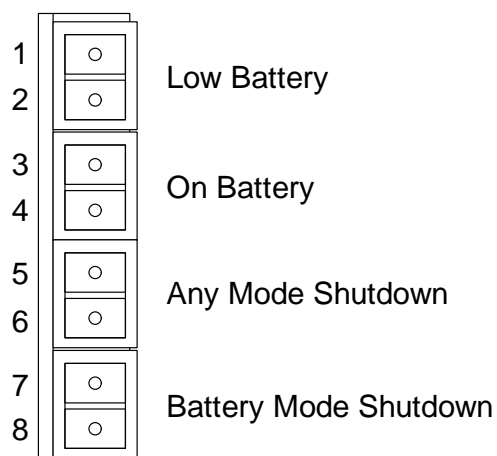

Table 4 Dry contact pin definitions

Pin	Definition
1 & 2	Low Battery Warning
3 & 4	On Battery Warning
5 & 6	Any Mode Shutdown
7 & 8	Battery Mode Shutdown

9.2.1 Any Mode Shutdown

The purpose of Any Mode Shutdown is to shut down the UPS output by turning Off the rectifier, inverter and static switch so that there is no power to the loads.

Any Mode Shutdown can be operated locally or remotely:

- Local Any Mode Shutdown can be performed by shorting Pin 5 and Pin 6.
- Remote Any Mode Shutdown can be performed using a switch connected to Pin 5 and Pin 6 and mounted at a remote location.

Activation of the Any Mode Shutdown will be logged as an event in the event history log.



NOTE

Remote Power Off will be performed either by NO or NC contact of Any Mode Shutdown.

The current limited source (+12VDC, 50mA) will be available from UPS.

The connection to UPS for remote connection will be via terminal block connector.

Any Mode Shutdown wiring must conform to all national, regional and local wiring codes and laws.



WARNING

When the Auto-enable output option is selected and the UPS output is disabled using Pin 5 and Pin 6, the Liebert GXT3-G's output can turn On automatically and without warning if the Pin 5 and Pin 6 connection is changed.

9.2.2 Battery Mode Shutdown

Battery Mode Shutdown permits shutting down the UPS by turning off the rectifier, inverter and static switch so that there is no power to the load when the UPS is On Battery. The auxiliary power for the UPS will still be active.

Battery Mode Shutdown can be performed locally or remotely:

- Local Battery Mode shutdown can be performed by shorting Pin 7 and Pin 8.
- Remote Battery Mode Shutdown can be performed using a switch connected to Pin 7 and Pin 8 and mounted at remote location.

Activation of the Battery Mode Shutdown will be logged as an event in the event history log.



NOTE

Remote Power Off will be performed by NO contact.

The current limited source (+12VDC, 50mA) will be available from UPS.

The connection to the Liebert GXT3 for remote connection will be via terminal block connector.

Battery Mode Shutdown wiring must conform to all national, regional and local wiring codes and laws.

This signal must last for 1.5 seconds or longer.

A battery shutdown signal will not cause an immediate shutdown. It will start a 2-minute shutdown timer. This timer cannot be stopped once triggered. If the utility power returns during this countdown, the Liebert GXT3 will still shut down and must remain shut down for 10 seconds. Whether the UPS turns back On when the power is restored depends on the auto-restart setting.

9.2.3 On Battery

On Battery signal is a Normally Open (NO) dry contact. When the UPS is supplying output power from the battery this dry contact will be closed.

9.2.4 Low Battery

Low Battery signal is a Normally Open (NO) dry contact. When the UPS is supplying output power from the battery and has reached the Low Battery Warning time selected in the configuration program, this dry contact will be closed.



NOTE

The rated values for the dry contacts are:

- *Rated Voltage: 5V*
- *Working Voltage Range: 4.5-10V*
- *Rated Current: 30ma*

9.3 Liebert IntelliSlot Communication Cards

The Liebert IntelliSlot port on the UPS accepts three optional cards:

- Liebert IntelliSlot SNMP Card
- Liebert IntelliSlot Relay Card
- Liebert IntelliSlot 485 Card.

The Liebert IntelliSlot SNMP Card provides SNMP monitoring and control of the UPS across the network.

The Liebert IntelliSlot Relay Card provides dry contact relay outputs for custom-wired applications and delivers support for built-in shutdown for AS/400 systems.

The Liebert IntelliSlot 485 Card is used to connect the UPS and computer system.

Follow instructions provided with the Liebert IntelliSlot card to configure Liebert MultiLink, the UPS or any additional ancillary product for the Liebert GXT3. These instructions are available at multilink.liebert.com

9.3.1 Liebert MultiLink

Liebert MultiLink continually monitors the UPS and can shut down your computer or server in the event of an extended power failure.

Liebert MultiLink can also be configured for use without the USB cable when the Liebert IntelliSlot SNMP/Web card is installed in the UPS. Additionally, Liebert MultiLink can be configured to coordinate shutdown across the network with other computers running Liebert MultiLink when you purchase a Liebert MultiLink License Kit. For more information about the Liebert IntelliSlot SNMP/Web Card and Liebert MultiLink License Kits, visit our Web site (www.liebert.com) or contact your local dealer or Emerson representative.

Several option cards are available for use in the Liebert IntelliSlot port of the Liebert GXT3. The Liebert IntelliSlot SNMP/Web Card provides SNMP and Web-based monitoring and control of the UPS across the network.

The Liebert IntelliSlot MultiPort 4 Card allows installing Liebert MultiLink software on four computers and coordinate shutdown in the event of a power failure.

The Liebert IntelliSlot Relay Card provides dry contact relay outputs for custom wired applications and delivers support for built-in shutdown for AS/400 systems.



CAUTION

To maintain safety (SELV) barriers and for electromagnetic compatibility, signal cables should be shielded and run separate from all other power cables, where applicable.

9.4 Remote Emergency Power Off

The UPS is equipped with a Remote Emergency Power Off (REPO) connector.

The user must supply a means of interfacing with the REPO circuit to allow disconnecting the UPS input feeder breaker to remove all sources of power to the UPS and connected equipment to comply with national and local wiring codes and regulations.

REPO switch connection diagram

UPS ships with REPO jumper installed allowing the UPS to operate

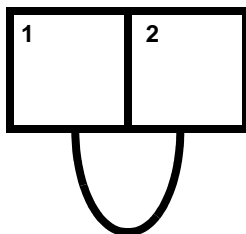

Normally closed switch system
(fail-safe)

Opening the REPO connection will disable the UPS. Manual restart using the front panel is required after the REPO connection is closed again.

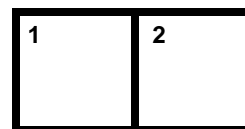

CAUTION

To maintain safety (SELV) barriers and electromagnetic compatibility, signal cables should be shielded and run separately from power cables.

10.0 MAINTENANCE

This section describes replacing the internal battery pack, precautions, checking the Liebert GXT3's status and checking UPS functions.

10.1 Replacing the Internal Battery Pack

The Liebert GXT3 is designed to allow the user to replace the internal battery pack safely. Read the safety cautions before proceeding. Contact your local dealer or Emerson representative to obtain the part number and pricing of the appropriate replacement battery pack.

10.1.1 Battery Replacement Procedures

1. Gently remove the front plastic bezel cover from the UPS.
2. Loosen and remove the six screws on the battery door, as shown in **Figure 16**.
3. Lay the battery door and screws aside for reassembly.

Figure 16 Removing the front plastic bezel cover and battery door

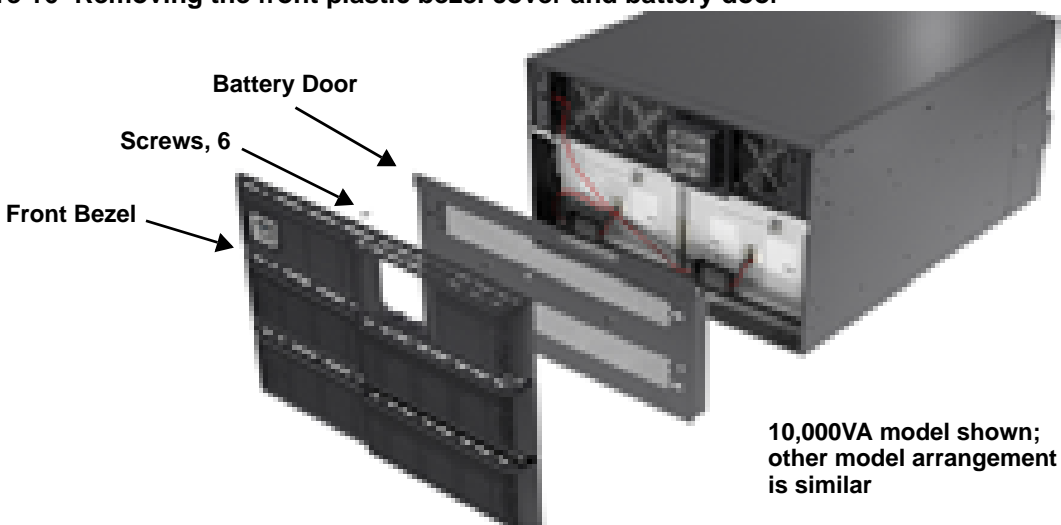

4. Gently pull the battery wires out and disconnect the battery connector, as shown in **Figure 17**.

Figure 17 Disconnecting the battery plug and battery receptacle (front view)

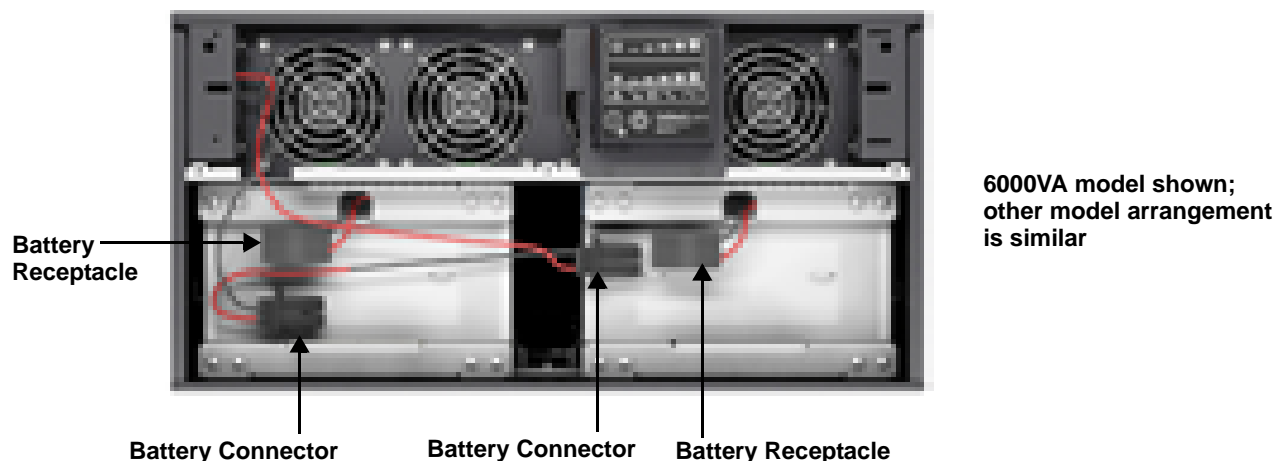

5. Grasp the battery handle and pull one of the internal battery packs out of the UPS, as shown in **Figure 18**.

Repeat this step if both battery packs will be replaced. Each model has two battery packs

Figure 18 Pulling out the battery packs

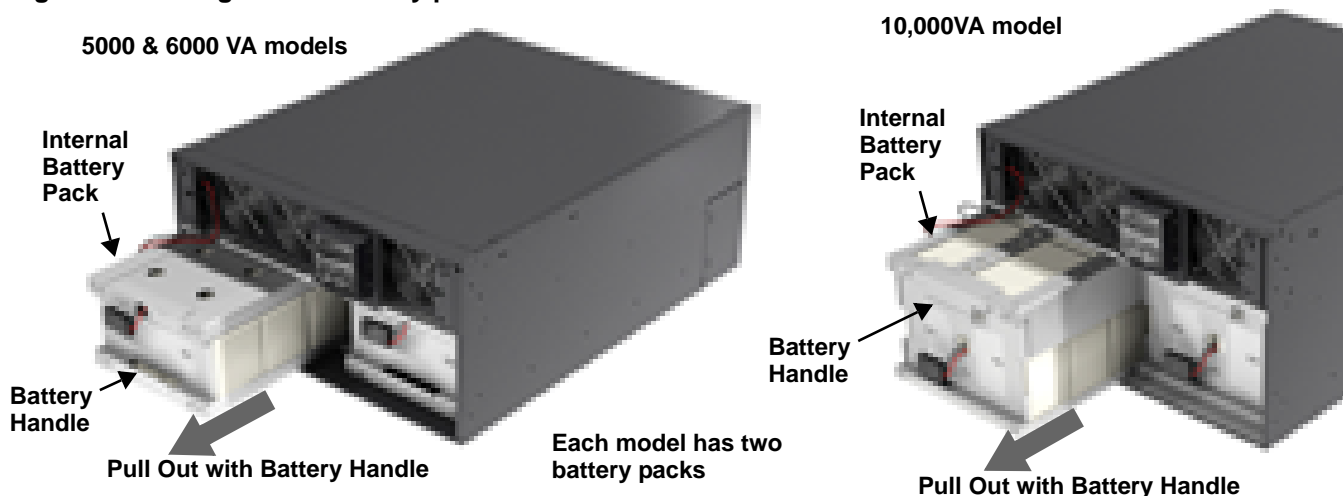

6. Unpack a new internal battery pack. Take care not to destroy the packing. Compare the new and old internal battery packs to make sure they are the same type and model. If they are the same, proceed with **Step 7**; if they are different, stop and contact your local Emerson representative or Emerson Channel Support.
7. Line up and slide in the new internal battery pack.
8. Repeat **Steps 6** and **7** if replacing both battery packs. Each model has two battery packs
9. Reconnect the battery plugs and battery receptacles.
10. Gently push the battery wire into the UPS battery compartment.
11. Reattach the front battery door with the six screws.
12. Reattach the front plastic bezel cover to the UPS.

**NOTE**

The internal battery pack is hot-swappable. However, caution should be exercised because the load is unprotected from disturbances and power failures during this procedure. Do not replace the battery while the UPS is operating in Battery Mode. This will result in a loss of output power and will drop the connected load.

10.2 Battery Charging

The batteries are valve-regulated, nonspillable, lead acid and should be kept charged to attain their design life. The Liebert GXT3 charges the batteries continuously when it is connected to the mains input power.

If the Liebert GXT3 will be stored for a long time, Emerson recommends connecting the UPS to input power for at least 24 hours every four to six months to ensure full recharge of the batteries.

10.3 Precautions

Although the Liebert GXT3 has been designed and manufactured to ensure personal safety, improper use can result in electrical shock or fire. To ensure safety, observe the following precautions:

- Turn Off and unplug the Liebert GXT3 before cleaning it.
- Wear rubber gloves and boots.
- Clean the UPS with a dry cloth. Do not use liquid or aerosol cleaners.
- Never block or insert any objects into the ventilation holes or other openings of the UPS.
- Do not place the Liebert GXT3 power cord where it might be damaged.

10.4 Checking UPS Status

Emerson recommends checking the UPS operation status every six months.

- Check whether the UPS is faulty: Is the Fault Indicator on? Is the UPS sounding an alarm?
- Check whether the UPS is operating in Bypass Mode. Normally, the UPS operates in Normal Mode. If it is operating in Bypass Mode, stop and contact your local Emerson representative, or Emerson Channel Support.
- Check whether the battery is discharging. When the mains input is normal, the battery should not discharge. If the UPS is operating in Battery Mode, stop and contact your local Emerson representative or Emerson Channel Support.

10.5 Checking UPS Functions



NOTE

UPS function check procedures may interrupt power supply to the connected load.

Emerson recommends checking the UPS functions once every six months.

Back up the load data before conducting the UPS functions check. Procedures are as follows:

1. Press the Standby/Manual Bypass button to check whether the buzzer and indicators are normal.
2. Press the On/Alarm Silence/Manual Battery Test button to check again whether the indicators are on and the UPS is operating normally.
3. Press the On/Alarm Silence/Manual Battery Test button for three seconds after Inverter Mode. The UPS should initiate a battery self-test. Check to determine whether the battery is operating normally. If not, stop and contact your local Emerson representative or Emerson Channel Support

11.0 TROUBLESHOOTING

This section indicates various UPS symptoms a user may encounter and provides a troubleshooting guide in the event the UPS develops a problem. Use the following information to determine whether external factors caused the problem and how to remedy the situation.

11.1 UPS Symptoms

The following symptoms indicate the Liebert GXT3 is malfunctioning:

- The relative indicators illuminate, indicating the UPS has detected a problem.
- An alarm buzzer sounds, alerting the user that the UPS requires attention.

11.1.1 Indicators

In addition to the fault indicator being illuminated, one or more of LED segments of battery level indicator will also be illuminated to provide a diagnostic aid to the user, as shown in **Figure 19**. The descriptions are listed in **Table 5**.

Figure 19 Battery level indicator

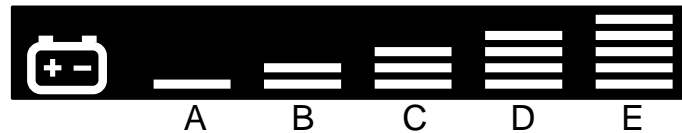

Table 5 Indicator descriptions

Indicator	Diagnosis/Audible alarm
A - E	On bypass from output overload (half-second beep every half second)
A	On bypass due to overtemperature condition (1-second beep every 4 seconds)
B	On bypass due to DC bus overvoltage (1-second beep every 4 seconds)
C	On bypass due to DC/DC power supply failure (1-second beep every 4 seconds)
D	PFC failure (1-second beep every 4 seconds).
E	On bypass due to inverter failure (1-second beep every 4 seconds)
A&C	UPS failed battery test (2-second beep every 60 seconds)
C&E	UPS shutdown by command from communication (USB port or Liebert IntelliSlot port) (no audible)
A&B	UPS Failure (includes dual-fan failure, single-fan failure under certain conditions and battery charger failure) and continuous alarm
Battery Indicator Flashing	Internal Battery source not available (continuous horn); check battery connection, power down and reboot UPS.
Bypass Indicator Flashing	Mains power voltage or frequency is out of tolerance; bypass is unavailable

A - E indicators are shown in **Figure 19**

11.1.2 Audible Alarm

An audible alarm will sound in conjunction with the visual indicators to indicate a change in UPS operating status. The audible alarm will sound as described in **Table 6**.

Table 6 Audible alarm description

Condition	Alarm
Battery discharge	Half-second beep every 10 seconds
Low battery	Two half-second beeps every 5 seconds
UPS fault, load on bypass	1-second beep every 4 seconds
UPS fault, no power to load	Continuous
Overload	Half-second beep every half second
Battery replacement	2-second beep every 60 seconds
Battery loss	Continuous
Wiring problem (loss of proper grounding for UPS)	Continuous
Bypass reminder	1-second beep every 2 minutes

11.2 Troubleshooting

In the event of an issue with the UPS, refer to **Table 7** to determine the cause and solution. If the fault persists, contact Emerson Channel Support.

Table 7 Troubleshooting table

Problem	Cause	Solution
UPS fails to start when the On/Alarm Silence/Manual Battery Test button is pressed	UPS is short-circuited or overloaded	Ensure UPS is Off. Disconnect all loads and ensure nothing is lodged in output receptacles. Ensure loads are not defective or shorted internally.
Battery indicator is illuminated	UPS is not plugged in	UPS is operating from battery mode. Ensure UPS is securely plugged into the wall receptacle.
	UPS input protection fuse has blown/opened	UPS is operating from battery mode. Save data and close applications. Replace UPS input fuse, then restart UPS.
	Mains power is out of tolerance	UPS is operating from battery mode. Save data and close applications. Ensure mains supply voltage is within acceptable limits for UPS.
UPS has reduced battery backup time	Batteries are not fully charged	Keep UPS plugged in continuously at least 24 hours to recharge batteries.
	UPS is overloaded	Check load level indicator and reduce the load on the UPS.
	Batteries may not be able to hold a full charge due to age	Replace batteries. Contact your local dealer, Emerson representative or Emerson Channel Support for replacement battery kit.
Fault and Bypass indicators and all LED segments of battery level indicator are illuminated	UPS is overloaded or load is faulty	Check load level indicator and remove non-essential loads. Recalculate the load and reduce number of loads connected to UPS. Check load for faults.
Fault and Bypass indicators and diagnostic A indicator are illuminated	UPS has been shut down due to temperature condition; load is on bypass power	Ensure UPS is not overloaded, ventilation holes are not blocked and room ambient temperature is not excessive. Wait 30 minutes to allow UPS to cool, then restart UPS. If UPS cannot restart, contact your local dealer, Emerson representative or Emerson Channel Support.
Fault and Bypass indicators and diagnostic B indicator are illuminated	UPS internal DC bus overvoltage	UPS requires service. Contact your local dealer, Emerson representative or Emerson Channel Support.

Table 7 Troubleshooting table (cont'd)

Problem	Cause	Solution
Fault and Bypass indicators and diagnostic C indicator are illuminated	UPS DC/DC fault	UPS requires service. Contact your local dealer, Emerson representative or Emerson Channel Support.
Fault indicator and diagnostic D indicator are illuminated	UPS PFC (Power Factor Correction Circuit) fault	UPS requires service. Contact your local dealer, Emerson representative or Emerson Channel Support.
Fault and Bypass indicators and diagnostic E indicator are illuminated	UPS inverter fault	UPS requires service. Contact your local dealer, Emerson representative or Emerson Channel Support.
Fault indicator and diagnostic A and C indicators are illuminated	UPS failed the battery test	Replace batteries. Contact your local dealer, Emerson representative or Emerson Channel Support.
Fault and Bypass indicators and diagnostic C and E indicators are illuminated	UPS has been shut down by a command from the communications port(s)	Your UPS has received a signal or command from the attached computer. If this was inadvertent, ensure the communication cable used is correct for your system. For assistance, contact your local dealer, Emerson representative or Emerson Channel Support.
Fault indicator and diagnostic A and B indicators are illuminated	UPS failure (includes dual-fan failure, single-fan failure under certain conditions and battery charger failure) and continuous alarm	Ensure fan is not blocked up. If the fault is not removed, contact your local dealer, Emerson representative or Emerson Channel Support.
AC input indicator is flashing.	UPS detected a line-to-neutral reversal or a loss of proper grounding for UPS; continuous horn and UPS cannot start up in standby status. This is active only when power is first applied to the input. Once the UPS is running, the AC input indicator will flash, unless the input wiring is correctly changed.	Contact a qualified electrician to verify site wiring.
Battery indicator is flashing.	Battery source is not available; continuous horn.	Check battery connections, completely power down and restart UPS. NOTE: If the battery circuit opens while the UPS is running, it will be detected when the next battery test is performed.
Bypass indicator is flashing.	Because the voltage or frequency is outside acceptable limits, the bypass is disabled.	The AC input powers the PFC input and serves as the bypass source. If the AC is present but the voltage or frequency exceeds the acceptable range for safe operation with a load, the bypass will be disabled and this indicator will flash, indicating that the bypass is unavailable.

When reporting a UPS issue to Emerson, include the UPS model and serial number. These are on the top panel of the Liebert GXT3.

12.0 SPECIFICATIONS

Table 8 UPS specifications

Model #	GXT3-5000RT230	GXT3-6000RT230	GXT3-10000RT230
Rating	5000VA/4000W	6000VA/4800W	10000VA/9000W
Dimensions, mm (in)			
Unit, W x D x H	570 x 430 x 220 (22.4 x 16.9 x 8.7)		577 x 430 x 261 (22.7 x 16.9 x 10.3)
Shipping, W x D x H	745 x 530 x 516 (29.3 x 20.9 x 20.3)		717 x 515 x 570 (28.2 x 20.3 x 22.4)
Weight, kg (lb)			
Unit	60 (132.2)		80 (176.4)
Shipping	71 (156.5)		82 (180.8)
Input AC Parameters			
Operating Frequency, Nom	50 or 60Hz (Factory Default = 50)		
Factory Default VAC	230VAC		
User-Configurable VAC	220/230/240VAC (May be modified using included configuration program)		
Operating Voltage Range Without Battery Operation	176 - 280VAC		
Maximum Allowable VAC	280VAC		
Input Frequency Without Battery Operation	40 - 70Hz		
Input Power Connection	PD2-CE6HDWRMBS Standard (See 3.3 - Removable Power Distribution Box)	PD2-CE10HDWRMBS Standard (See 3.3 - Removable Power Distribution Box)	
Output AC Parameters			
Factory Default VAC	230VAC		
Output Connections	PD2-CE6HDWRMBS Standard (See 3.3 - Removable Power Distribution Box)	PD2-CE10HDWRMBS Standard (See 3.3 - Removable Power Distribution Box)	
Frequency	50Hz or 60Hz, Nominal		
Waveform	Sinewave		
Main Mode Overload	>200% for 5 cycles; 151 - 200% for 1 seconds; 131-150% 10 seconds; 105 - 130% 1 minute		
Battery Parameters			
Type	Valve-regulated, non-spillable, lead acid		
Quantity x V	20 x 12V		
Battery Mfr. / Part #	5AH battery, CSB HR1221W or YUASA NPH5-12	9AH battery, CSB HR1234W or Panasonic UP-RW1245	
Backup Time	See Table 12 - Battery run time, minutes, for 5000 and 6000VA UPS models and Table 13 - Battery run time, minutes, for 10,000VA UPS models		
Recharge Time (Internal Batteries)	3 hr. to 90% capacity after full discharge into 100% load		
Bypass Protection Limits			
Disable Bypass Operation	If input voltage exceeds $\pm 15\%$ of the nominal voltage		
Re-Enable Bypass Operation	If input voltage returns to within $\pm 10\%$ of nominal output voltage		
Disable Bypass operation	When the input frequency prevents synchronous operation		
Environmental			
Operating Temperature, °C (°F)	0 to 40 (32 to 104) see Table 9 - Operating temperature parameters		
Storage Temperature, °C (°F)	-15 to 50 (5 to 122)		
Relative Humidity	0-95% non-condensing		
Operating Elevation	Up to 1000m (3281 ft) at 30°C (86°F) without derating		
Audible Noise	<55 dBA, at 1 meter from the rear <50 dBA, at 1 meter from the front or sides		

Table 8 UPS specifications (cont'd)

Model #	GXT3-5000RT230	GXT3-6000RT230	GXT3-10000RT230
Agency			
Safety	IEC62040-1:2008 version		
EMI/EMC	IEC/EN/AS 62040-2 2nd Ed (Cat 2 – Table 6)		
ESD	EN61000-4-2, Level 4, Criteria A		
Radiated Susceptibility	EN61000-4-3, Level 3, Criteria A		
Electrical Fast Transient	EN61000-4-4, Level 4, Criteria A		
Surge Immunity	EN61000-4-5, Level 3, Criteria A		
Transportation	ISTA Procedure 1A		

Table 9 Operating temperature parameters

Ambient Temperature, °C (°F)	pf @30°C ±3°C (pf @ 86°F ±5.4°F)	pf @40°C ±3°C (pf @ 104°F ±5.4°F)
5000RT230, 6000RT230	0.8pf	0.8pf
10000RT230	0.9pf	0.8pf

Table 10 Power distribution specifications

Model Number	PD2-CE6HDWRMBS	PD2-CE10HDWRMBS
Amp Rating	32 Amps	63 Amps
Input Power Connection	3-Wire Hard-Wired, 6-10mm ² (8-10AWG)	
Output Power Connection	3-Wire Hard-Wired, 6-10mm ² (8-10AWG)	
Includes:	Two IEC320 C19 16A/250V Sockets Eight C13 10A/250V Sockets Manual Bypass Switch with Indicator Lamps	Four IEC320 C19 16A/250V Sockets, Four C13 10A/250V Sockets Manual Bypass Switch with Indicator Lamps
Input Branch Circuit Breaker, Supplied by User	32A	63A

Table 11 External battery cabinet specifications

Model Number	GXT3-240VBATTCE	GXT3-240RTVBATT
Used with UPS Model	GXT3-5000RT230 GXT3-6000RT230	GXT3-10000RT230
Dimensions, W x D x H, mm (in.)		
Unit (with bezel)	570 x 430 x 148 (22.4 x 16.9 x 5.8)	577 x 430 x 173 (22.7 x 16.9 x 6.8)
Shipping	745 x 530 x 407 (29.3 x 20.8 x 16)	745 x 530 x 475 (29.3 x 20.8 x 18.7)
Weight, kg (lb)		
Unit	50.4 (111)	52.6 (116)
Shipping	54 (119)	76 (167.6)
Battery Parameters		
Type	Valve-regulated, non-spillable, lead acid	
Quantity x V	1 x 20 x 12V	
Battery Manufacturer, Part #	Yuasa/NPH5-12	CSB HR 1234W
Backup Time	See Tables 12 and 13	
Environmental		
Operating Temp, °C (°F)	0 to 40 (32 to 104) see Table 9 - Operating temperature parameters	
Storage Temp, °C (°F)	-15 to 50 (5 to 122)	
Relative Humidity	0-95% non-condensing	
Operating Elevation	Up to 1000m (3280.83 ft.) at 40°C (104°F)	
Agency		
Safety	IEC62040-1:2008 version	
Transportation	ISTA Procedure 1A	

Table 12 Battery run time, minutes, for 5000 and 6000VA UPS models

Number of Batteries	UPS Model	Output to Connected Load, W									100% load W
		1400	1800	2200	2600	3000	3400	3800	4200	4600	
Internal Battery	GXT3-5000RT230	28	18	14	11	9.5	7.5	6.5	5	—	4000
	GXT3-6000RT230	28	18	14	11	9.5	7.5	6.5	5	4	4800
Internal Battery + 1 External Battery Cabinet	GXT3-5000RT230	56	36	28	22	19	15	13	10	—	4000
	GXT3-6000RT230	56	36	28	22	19	15	13	10	8	4800
Internal Battery + 2 External Battery Cabinet	GXT3-5000RT230	84	54	42	33	28.5	22.5	19.5	15	—	4000
	GXT3-6000RT230	84	54	42	33	28.5	22.5	19.5	15	12	4800
Internal Battery + 3 External Battery Cabinets	GXT3-5000RT230	112	72	56	44	38	30	26	20	—	4000
	GXT3-6000RT230	112	72	56	44	38	30	26	20	16	4800
Internal Battery + 4 External Battery Cabinet	GXT3-5000RT230	140	80	70	55	47.5	37.5	32.5	25	—	4000
	GXT3-6000RT230	140	80	70	55	47.5	37.5	32.5	25	20	4800

Table 13 Battery run time, minutes, for 10,000VA UPS models

Number of Batteries	UPS Model	Output to Connected Load, W											100% load W
		3000	3600	4200	4800	5400	6000	6600	7200	7800	8400	9000	
Internal Battery	GXT3-10000RT230	19	14.5	11.5	10	8.5	7	6	5	4	3.5	3	9000
Internal Battery + 1 External Battery Cabinet	GXT3-10000RT230	38	29	23	20	17	14	12	10	8	7	6	9000
Internal Battery + 2 External Battery Cabinet	GXT3-10000RT230	57	43.5	34.5	30	25.5	21	18	15	12	10.5	9	9000
Internal Battery + 3 External Battery Cabinet	GXT3-10000RT230	76	58	46	40	34	28	24	20	16	14	12	9000
Internal Battery + 4 External Battery Cabinet	GXT3-10000RT230	95	72.5	57.5	50	42.5	35	30	25	20	17.5	15	9000

Using the configuration program, the user may specify the number of GXT3-240VBATT external battery cabinets attached to the UPS. The factory default is programmed for internal batteries only.

See **Tables 12** and **13** show the estimated run times at different loads.

12.1 Auto-Learning Battery Run Times

As batteries age, the estimated runtimes may become less accurate. The Liebert GXT3 is programmed to “learn” from a full battery discharge and modify the estimated runtime for the measured battery capacity. This can improve accuracy and compensate for aging batteries or batteries that operate at different ambient temperatures.

The UPS will update the anticipated run time calculation only under certain conditions.

- The UPS must have a steady load that is greater than 20%.
- The UPS must be at 100% charge at the start of a battery discharge.
- The battery discharge must continue uninterrupted until the batteries reach their end-of-discharge voltage.

If all conditions are not met, the run time calculation will not be modified.

If the configuration program is used to change the number of battery cabinets, then the values in the battery above table will be restored. This will override any value that is Auto-Learned.

Ensuring The High Availability Of Mission-Critical Data And Applications.

Emerson Network Power, the global leader in enabling business-critical continuity, ensures network resiliency and adaptability through a family of technologies—including Liebert power and cooling technologies—that protect and support business-critical systems. Liebert solutions employ an adaptive architecture that responds to changes in criticality, density and capacity. Enterprises benefit from greater IT system availability, operational flexibility and reduced capital equipment and operating costs.

Technical Support / Service

Web Site

www.liebert.com

Monitoring

liebert.monitoring@emerson.com

800-222-5877

Outside North America: +00800 1155 4499

Single-Phase UPS & Server Cabinets

liebert.upstech@emerson.com

800-222-5877

Outside North America: +00800 1155 4499

Three-Phase UPS & Power Systems

800-543-2378

Outside North America: 614-841-6598

Environmental Systems

800-543-2778

Outside the United States: 614-888-0246

Locations

United States

1050 Dearborn Drive

P.O. Box 29186

Columbus, OH 43229

Europe

Via Leonardo Da Vinci 8

Zona Industriale Tognana

35028 Piove Di Sacco (PD) Italy

+39 049 9719 111

Fax: +39 049 5841 257

Asia

29/F, The Orient Square Building

F. Ortigas Jr. Road, Ortigas Center

Pasig City 1605

Philippines

+63 2 687 6615

Fax: +63 2 730 9572

While every precaution has been taken to ensure the accuracy and completeness of this literature, Liebert Corporation assumes no responsibility and disclaims all liability for damages resulting from use of this information or for any errors or omissions.

© 2009 Liebert Corporation

All rights reserved throughout the world. Specifications subject to change without notice.

® Liebert is a registered trademark of Liebert Corporation.

All names referred to are trademarks or registered trademarks of their respective owners.

SLI-23185_REV0_2-10

Emerson Network Power.

The global leader in enabling *Business-Critical Continuity*™

- AC Power
- Embedded Computing
- Outside Plant
- Racks & Integrated Cabinets
- Connectivity
- Embedded Power
- Power Switching & Controls
- Services
- DC Power
- Infrastructure Management & Monitoring
- Precision Cooling
- Surge Protection